

Reverse osmosis systems osmoliQ:LB

Intended use

The reverse osmosis system osmoliQ:LB is designed for the demineralisation of raw water whose composition complies with the quality requirements of the German Drinking Water Ordinance (TrinkwV).

Application limits

Total hardness	< 0.1 °dH < 0.18 f < 0.018 mol/m ³ ¹⁾
Free chlorine	not detectable
Iron	< 0.10 mg/l
Manganese	< 0.05 mg/l
Silicate	< 15 mg/l
Chlorine dioxide	not detectable
Turbidity	< 1 NTU
Silt density index	< 3
pH range	6.5 – 8.5
Total salt concentration as NaCl	< 1000 mg/l
Feed water temperature ²⁾	10 – 30 °C

¹⁾ Not applicable for antiscalant option

²⁾ For feed water temperatures > 20 °C, a separate system design is required.

Function

The osmoliQ:LB works according to the reverse osmosis process.

Via a fine filter, the feed water is directed to the high-pressure pump which is protected from running dry by means of an optical sensor. The frequency converter and the control unit ensure a constant permeate capacity.

The feed water is directed to the reverse osmosis membranes via the pumps and is divided into the partial flows “permeate” and “concentrate”. Via a regulating valve, a partial flow of the concentrate is automatically recirculated to the feed water.

The remaining concentrate is measured by a flow meter and directed to the drain via an automatic control.

After each operating period (permeate tank full), the remaining constituents are flushed from the osmoliQ:LB via an automatic fitting.

Antiscalant option

For additional protection of the reverse osmosis membranes, a dosing-monitored diaphragm dosing pump adds a hardness stabiliser in proportion to the quantity.

Design

- Anodised aluminium rack with levelling feet (two-piece rack as of osmoliQ:LB20000)
- Side port pressure pipes made of GRP
- Ultra-low-pressure reverse osmosis membranes – KTW-approved
- PE piping with PP plug-in system for fittings or welded, to control the water flow – KTW-approved
- High-pressure centrifugal pump made of stainless steel 1.4404 (V4A) including dry-run protection and electric motor (efficiency class IE3) as well as frequency converter
- Fine filter with pressure gauge
- Power distribution with mains switch and automatic circuit breakers as central feeding point for power supply provided by client on site

Fittings

- Automatic fittings for feed water inlet and for concentrate flushing
- Pressure gauge for feed water, operating and concentrate pressure
- Pressure sensor for the continuous measuring of the operating pressure

• Product Data Sheet

Reverse osmosis systems osmoliQ:LB

- Vortex flow sensors (wear-free) for volume measurement (as of osmoliQ:LB20000: measurement of permeate flow as ultrasound flow meter)
- Ventilation device for concentrate pipe provided by client on site
- Stainless steel sampling valves for feed water, permeate and concentrate
- Sampling valves for each pressure pipe
- Shut-off valve at system inlet

Control unit

- Switch cabinet made of sheet steel, with front door
- Touchscreen (4.3") to indicate the operating state
- Quality control of permeate by means of conductivity meter
- Voltage-free contacts to relay pre-alarms and for safety shutdowns

- Digital input for smart metering
- Fully automatic monitoring and controlling of the system parameters
- Logging of measured data on integrated SD card
- Modbus RTU
- Possibility to interconnect and remotely control systems installed upstream or downstream
- Voltage-free collective fault signal for transfer to on-site central control stations/DDC systems
- Control of recovery, concentrate recirculation and permeate capacity via the pump frequency

Scope of supply

- Reverse osmosis system osmoliQ :LB – complete with internal piping and wiring, workshop-testing and preservation
- Optionally equipped with antiscalant dosing
- Operation manual

Technical specifications I

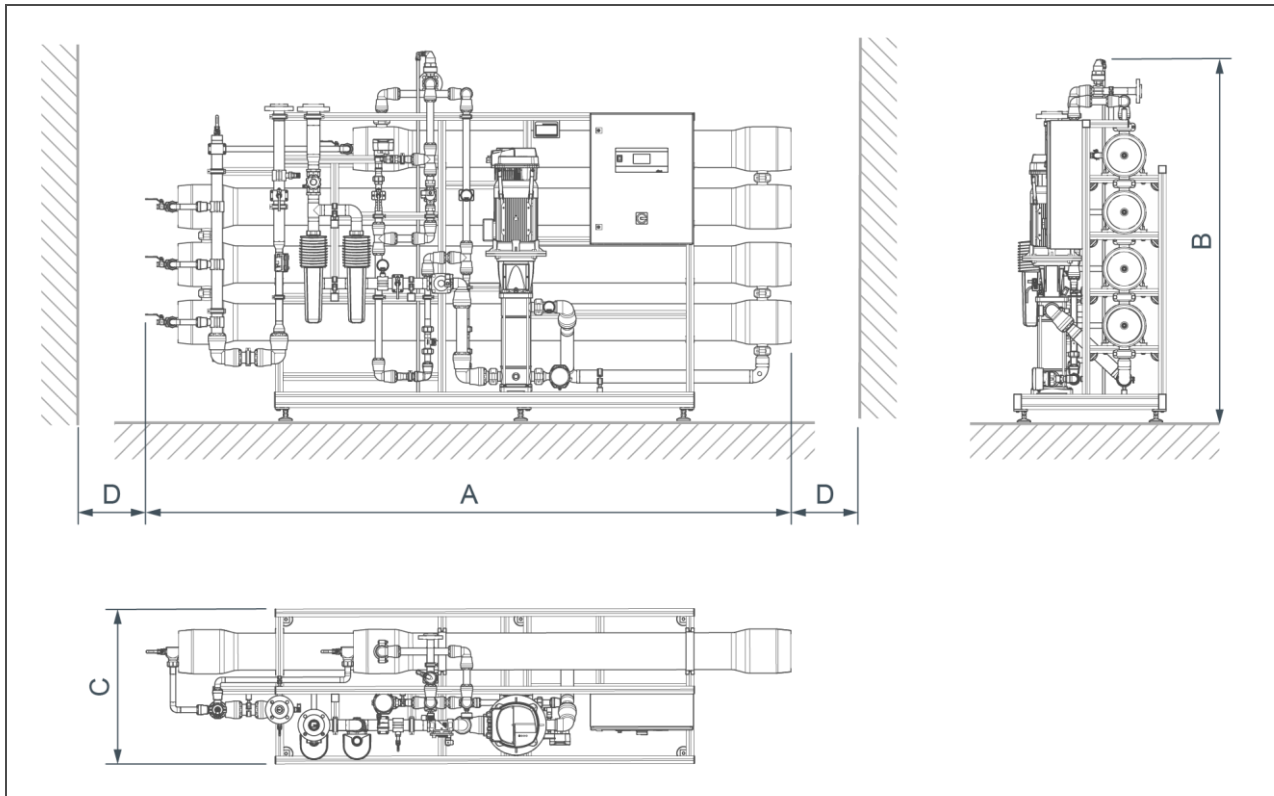

Dimensions and weights		LB4000	LB7000	LB10000	LB12000
A System width	mm	3700			
B System height	mm	2050			
C System depth	mm	900			
D Distance to wall (to remove RO modules)	mm	1200			
Room height/installation height	mm	≥ 2500			
Empty weight, approx.	kg	425	520	625	700
Operating weight, approx.	kg	485	600	725	830

Dimensions and weights		LB16000	LB20000	LB25000	LB30000
A System width	mm	3700	4700	4700	4700
B System height	mm	2150	2200	2200	2200
C System depth	mm	900	1500	1500	1500
D Distance to wall (to remove RO modules)	mm	1200			
Room height/installation height	mm	≥ 2500			
Empty weight, approx.	kg	800	1100	1415	1670
Operating weight, approx.	kg	950	1290	1675	2000

Technical specifications II LB4000 – LB12000

Connection data		LB4000	LB7000	LB10000	LB12000
Nominal connection diameter of feed water inlet (flange PN 10)		DN 40	DN 40	DN 50	DN 50
Nominal connection diameter of permeate outlet (flange PN 10)		DN 32	DN 40	DN 50	DN 50
Nominal connection diameter of concentrate outlet (flange PN 10)		DN 25			
Drain connection		DN 70			
Connected load, approx.	kW	4.2	5.3	6.7	7.1
Mains supply	V/Hz	400/50 - 60			
Phases		3P/N/PE			
Protection/protection class		IP 54/⊕			

Performance data		LB4000	LB7000	LB10000	LB12000
Permeate capacity at a recovery of 80 % (at 15 °C)	m³/h	4	7	10	12
Inlet flow pressure of feed water	bar	1.0 - 5.0			
Outlet pressure of permeate, approx.	bar	0.5 – 1.5			
Nominal pressure		PN 16			
Salt rejection	%	95 – 99			
Total salt concentration in feed water as NaCl	ppm	≤ 1000			
Silt density index (SDI)		< 3			
Recovery (adjustable)	%	50 – 80			
Concentrate volume flow at a recovery of 80 % (at 15 °C)	m³/h	1	1.75	2.5	3
Feed water volume flow at a recovery of 80 % (at 15 °C)	m³/h	5	8.75	12.5	15

General data		LB4000	LB7000	LB10000	LB12000
Feed water temperature	°C	10 – 30 ³⁾			
Ambient temperature	°C	5 – 35			
Humidity (non-condensing)	%	≤ 70			
Order no.		755 500	755 510	755 520	755 530

³⁾ For feed water temperatures > 20 °C, a separate system design is required.

Technical specifications III LB16000 – LB30000

Connection data		LB16000	LB20000	LB25000	LB30000
Nominal connection diameter of feed water inlet (flange PN 10)		DN 65	DN 80	DN 80	DN 100
Nominal connection diameter of permeate outlet (flange PN 10)		DN 50	DN 65	DN 80	DN 80
Nominal connection diameter of concentrate outlet (flange PN 10)		DN 25			
Drain connection		DN 100			
Connected load, approx.	kW	9.4	12	9.6	10.1
Mains supply	V/Hz	400/50 – 60			
Phases		3P/N/PE			
Protection/protection class		IP 54/⊕			

Performance data		LB16000	LB20000	LB25000	LB30000
Permeate capacity at a recovery of 80 % (at 15 °C)	m ³ /h	16	20	25	30
Inlet flow pressure of feed water	bar	1.0 – 5.0			
Outlet pressure of permeate, approx.	bar	0.5 – 1.5			
Nominal pressure		PN 16			
Salt rejection	%	95 – 99			
Total salt concentration in feed water as NaCl	ppm	≤ 1000			
Silt density index (SDI)		< 3			
Recovery (adjustable)	%	50 – 80			
Concentrate volume flow, 80 % recovery	m ³ /h	4	5	6.25	7.5
Feed water volume flow, 80 % recovery	m ³ /h	20	25	31.25	37.5

General data		LB16000	LB20000	LB25000	LB30000
Feed water temperature	°C	10 – 30 ⁴⁾			
Ambient temperature	°C	5 – 35			
Humidity (non-condensing)	%	≥ 70			
Order no.		755 540	755 550	755 560	755 570

⁴⁾ For feed water temperatures > 20 °C, a separate system design is required.

Installation example osmoliQ:LB4000

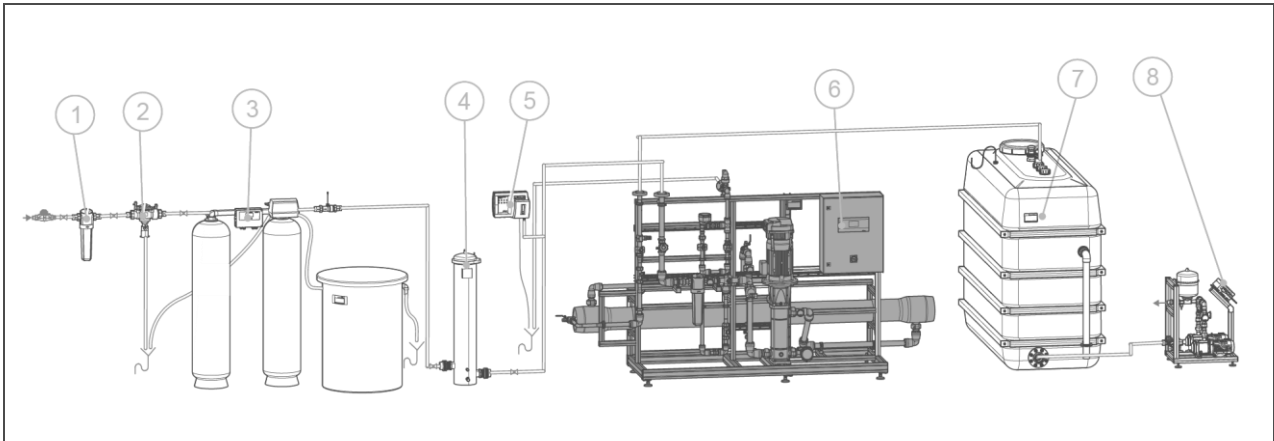

Item	Designation	Item	Designation
1	Fine filter BOXER KX	2	System separator GENO-DK 2
3	Water softener GENO-mat duo WE-X 450	4	GENO-activated carbon filter AKF 6000
5	Hardness control measuring device softwatch	6	Reverse osmosis system osmoliQ:LB4000
7	Basic pure water tank K-X 4000	8	Pressure booster system GENO FU-X 4/40-2 N

Installation example osmoliQ:LB7000

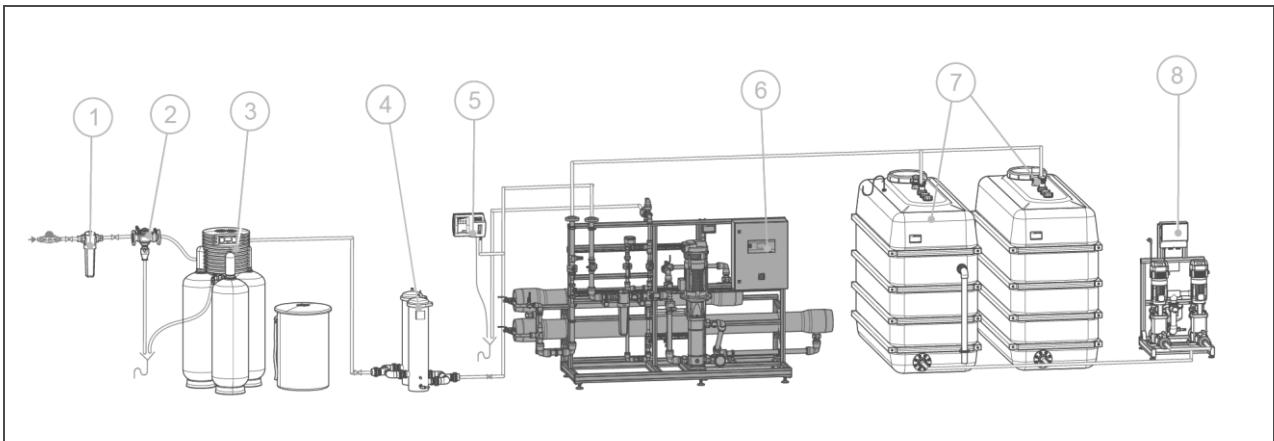

Item	Designation	Item	Designation
1	Fine filter BOXER KX	2	System separator GENO-DK 2
3	Water softener Delta-p 2" - I	4	2 GENO-activated carbon filters AKF 9000
5	Hardness control measuring device softwatch	6	Reverse osmosis system osmoliQ:LB7000
7	Basic pure water tank K-X 4000 with additional tank K 4000	8	Pressure booster system GENO FU-X 10/40-2 N

Installation example osmoliQ:LB10000 with antiscalant dosing

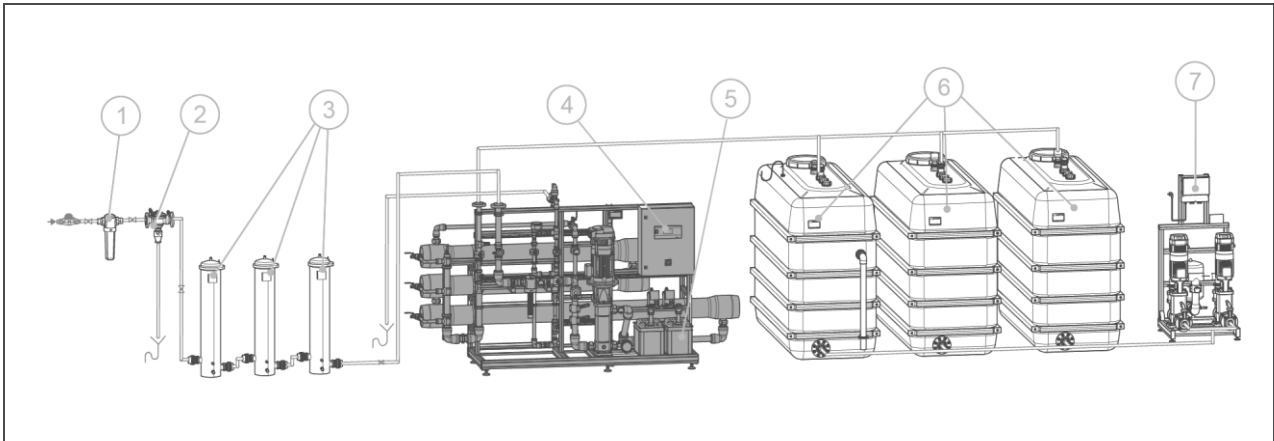

Item	Designation	Item	Designation
1	Fine filter BOXER KX	2	System separator GENO-DK 2 2"
3	3 GENO-activated carbon filters AKF 4500	4	Reverse osmosis system osmoliQ:LB10000
5	Antiscalant dosing system	6	Basic pure water tank K-X 4000 with 2 additional tanks K 4000
7	Pressure booster system GENO FU-X 16/40-2 N		

Requirements for the installation site

Obey the local installation directives, general guidelines and technical specifications.

- Protection from frost, severe heat exposure and direct sunlight
- Protection from chemicals, dyes, solvents and their vapours
- Ambient temperature and radiation temperature in the immediate vicinity
 - $\leq 25\text{ °C}$ for applications in the drinking water sector
 - $\leq 35\text{ °C}$ for purely technical applications
- Access for maintenance work (take note of space required)
- Horizontal installation surface with sufficient load-bearing capacity to support the operating weight of the product
- Chemical-resistant installation surface (resistant to acids, bases)

Water installation

- Drinking water filter installed upstream and pressure reducer, if necessary (e.g. fine filter BOXER KX/KDX)
- Euro system separator installed upstream (e. g. GENO-DK 2 or GENO-DK 2-Maxi)
- Activated carbon filter or liquid dosing to reduce oxidants, if necessary
- Water softener or antiscalant dosing
- Floor drain or corresponding safety device with water stop function
- Salt water resistant lifting system in case the drain connection is located at a higher level
- Drain connection (dimensioning according to Technical specifications)

Electrical installation

- On-site mains outlet 3 x 400 V/50 Hz/ 3 phases/N/PE
- On-site mains fuse protection by means of AC/DC sensitive RCCB with a response threshold of 300 mA

Accessories

Drinking water filter

Fine filter BOXER KX

GENO-fine filter FME (50 µm)

– please inquire –

For prefiltration of undissolved impurities

Euro system separator

GENO-DK 2-Maxi

– please inquire –

To secure systems and devices as per DIN EN 1717

Water softener

GENO-mat duo WE-X

Delta-p - I

softliQ:XLA

– please inquire –

To soften the feed water of the reverse osmosis systems to < 0.1 °dH

Hardness control measuring device softwatch

Order no. 17260000000

For automatic monitoring of the residual/total hardness (water hardness) via limit value indicator

GENO-activated carbon filter AKF

– please inquire –

To reduce the chlorine concentration

Dosing system

For hardness stabilisation. System with microprocessor-controlled diaphragm dosing pump and dosing monitoring

Single system

Order no. 755 800

Twin system

Order no. 755 810

Basic pure water tank K-X

– please inquire –

Rectangular tank for pure water supply of 1100, 1500, 2000, 2500, 3000 and 4000 litres

Basic pure water tank

KR series

– please inquire –

Tank version: cylindrical with conical roof, made of black PE-HD or grey PP

Pressure booster system

– please inquire –

Vertical high-pressure circulation pumps with standard suction and frequency converter. Pump system pre-assembled on aluminium rack with optionally selectable piping material for the system, with microprocessor controller

Delivery rates 2.4 – 40 m³/h

Options for control unit

– please inquire –

Communication module

Profibus DP

Order no. 750 160

For connection to a profibus DP “master”

Communication module

BACnet IP

Order no. 750 170

For connection to a BACnet IP “master”

Voltage-free signals

Order no. 750 180

For connection to a building/central control system

Analogue signals 4 - 20 mA

Order no. 750 185

For connection to a building/central control system

Contact

Grünbeck Wasseraufbereitung GmbH
Josef-Grünbeck-Str. 1
89420 Hoehstaedt
GERMANY

☎ +49 9074 41-0

☎ +49 9074 41-100

✉ info@gruenbeck.com
www.gruenbeck.com

