

We understand water.

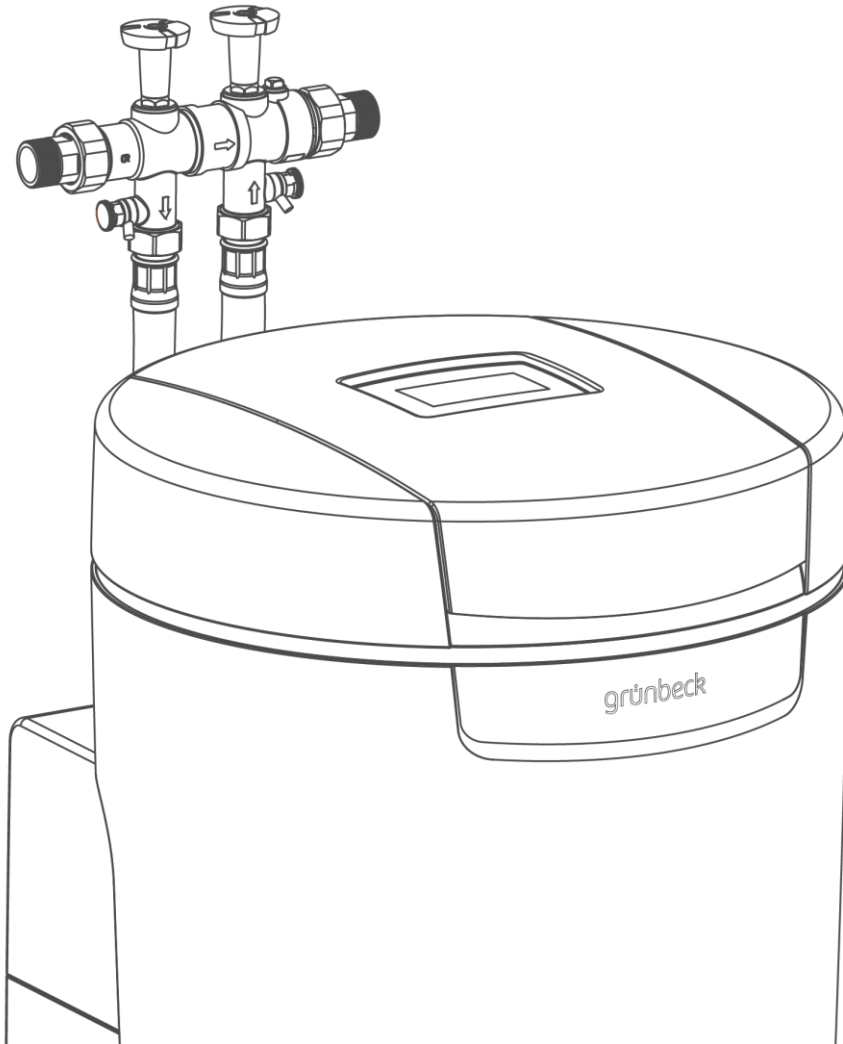

Water softener | softliQ:MD12i

Operation manual

grünbeck

General Contact
Germany

International Sales
Phone +49 9074 41-145

Technical Service
Phone +49 9074 41-333
Fax +49 9074 41-120

Availability
Monday to Thursday
7:00 am - 6:00 pm

Friday
7:00 am - 4:00 pm

We reserve the right to technical modifications.
© by Grünbeck Wasseraufbereitung GmbH

Original operation manual
Edition: February 2024
Order no.: 100097340000_en_084

Table of contents

1	Introduction	4	7	Operation	28
1.1	Validity of the manual	4	7.1	Touch display	28
1.2	Product identification	4	7.2	Menu structure.....	31
1.3	Symbols used	5	7.3	Connection to Grünbeck Cloud	33
1.4	Depiction of warnings	6	7.4	Refilling salt tablets.....	35
1.5	Demands on personnel.....	6	7.5	Starting a manual regeneration	36
			7.6	Determining and entering the water hardness.....	36
2	Safety	8	7.7	Setting the blending valve	38
2.1	Safety measures	8	7.8	Installer level (Code 005).....	38
2.2	Product-specific safety instructions	9			
3	Product description	10	8	Maintenance and repair	41
3.1	Intended use	10	8.1	Cleaning	41
3.2	Product components	11	8.2	Intervals	42
3.3	Functional description	13	8.3	Inspection	42
3.4	Admissible regenerant	13	8.4	Maintenance	43
3.5	Product registration.....	14	8.5	Consumables.....	44
3.6	Accessories	14	8.6	Spare parts	44
3.7	Inputs and outputs of the control unit.....	16	8.7	Wearing parts	45
4	Transport, set-up and storage	18	9	Troubleshooting	46
4.1	Shipping/delivery/packaging	18	9.1	Display messages	46
4.2	Transport/Set-up	18	9.2	Other observations	49
4.3	Storage	18	10	Decommissioning	50
5	Installation	19	10.1	Temporary standstill	50
5.1	Requirements for the installation site.....	20	10.2	Final shutdown	50
5.2	Checking the scope of supply	21	11	Dismantling and disposal	51
5.3	Installing the product.....	22	11.1	Deleting personal data.....	51
6	Start-up/commissioning	25	11.2	Dismantling	51
6.1	Starting up the product	25	11.3	Disposal	52
6.2	Handing over the product to the owner/operator/ operating company	27	12	Technical specifications	53
			13	Operation log	55

1 Introduction

This manual is intended for owners/operators/operating companies, users as well as qualified specialists and ensures the safe and efficient handling of the product. The manual is an integral part of the product.

- ▶ Carefully read this manual and the included manuals on the components before you operate your product.
- ▶ Obey all safety and handling instructions.
- ▶ Keep this manual and all other applicable documents, so that they are available when needed.

Illustrations in this manual are for basic understanding and can differ from the actual design.

1.1 Validity of the manual

This manual applies to the product below:

- Water softener softliQ:MD12i
- Water softener softliQ:MD12i Gastronomy

1.2 Product identification

You can identify your product based on the product designation and the order no. shown on the type plate.

- ▶ Check whether the products given in chapter 1.1 correspond to your product.

The type plate is located on the inside of the brine tank lid.

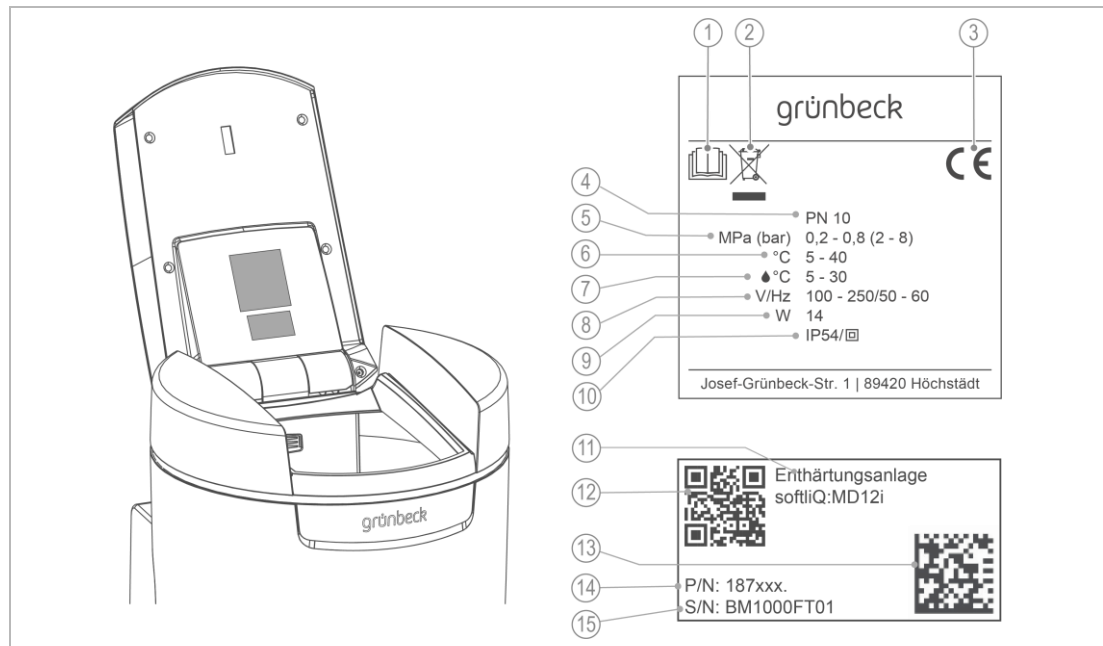

Designation	
1	Obeý the operation manual
2	Disposal information
3	CE mark
4	Nominal pressure
5	Operating pressure
6	Ambient temperature
7	Water temperature
8	Rated voltage range/frequency

Designation	
9	Rated load
10	Protection/protection class
11	Product designation
12	QR code
13	Data matrix code
14	Order no.
15	Serial no.

1.3 Symbols used

Symbol	Meaning
	Danger and risk
	Important information or requirement
	Useful information or tip
	Written documentation required
	Work that must be carried out by qualified specialists only
	Work that must be carried out by technical service personnel only

1.4 Depiction of warnings



This manual contains information and instructions that you must obey for your personal safety. The information and instructions are highlighted by a warning symbol and are structured as shown below:



SIGNAL WORD Type and source of hazard

- Possible consequences
- ▶ Preventive measures

The following signal words are defined subject to the degree of danger and might be used in the present document:

Warning symbol and signal word		Consequences if the information/ instructions are ignored
 DANGER		Death or serious injuries
 WARNING	Personal injury	Possible death or serious injuries
 CAUTION		Possible moderate or minor injuries
NOTE	Damage to property	Possible damage to components, the product and/or its functions, or an object in its vicinity

1.5 Demands on personnel

During the individual life cycle phases of the product, different people carry out activities on the product. The respective tasks require different skills.

1.5.1 Qualification of personnel

Personnel	Requirements
User	<ul style="list-style-type: none"> • No special expertise required • Knowledge of the tasks assigned • Knowledge of possible dangers in case of incorrect behaviour • Knowledge of necessary protective equipment and protective measures • Knowledge of residual risks
Owner/operator/ operating company	<ul style="list-style-type: none"> • Product-specific expertise • Knowledge of statutory regulations on work safety and accident prevention
Qualified specialist Electrical engineering Sanitary engineering (plumbing and HVAC) Transport	<ul style="list-style-type: none"> • Professional training • Knowledge of relevant standards and regulations • Knowledge of detection and prevention of potential hazards • Knowledge of statutory regulations on accident prevention
Technical service (Grünbeck's technical service/authorised service company)	<ul style="list-style-type: none"> • Extended product-specific expertise • Trained by Grünbeck

1.5.2 Authorisations of personnel

The table below describes which tasks must be carried out by whom.

	User	Owner/ operator/ operating company	Qualified specialist	Technical service
Transport and storage		X	X	X
Installation and mounting			X	X
Start-up			X	X
Operation and handling	X	X	X	X
Cleaning	X	X	X	X
Inspection	X	X	X	X
Maintenance		X	X	X
semi-annually				
annually				X
Troubleshooting	X	X	X	X
Repair				X
Decommissioning and restart/recommissioning			X	X
Dismantling and disposal			X	X

2 Safety

2.1 Safety measures

- Only operate your product if all components are installed properly.
- Obey the local regulations on drinking water protection, accident prevention and occupational safety.
- Do not make any changes, alterations, extensions or program changes on your product.
- Only use genuine spare parts for maintenance or repair.
- Keep the premises locked against unauthorised access to protect imperilled or untrained persons from residual risks.
- Comply with the maintenance intervals (refer to chapter 8.2). Failure to comply can result in microbiological contamination of your drinking water system.

2.1.1 Mechanical hazards

- You must never remove, bridge, or otherwise tamper with safety equipment.
- For all work on the product that cannot be carried out from the ground, use stable, safe and self-standing access aids (e.g. stepladders).

2.1.2 Pressure-related hazards

- Components can be under pressure. There is a risk of injuries and damage to property due to escaping water and unexpected movement of components. Check the pressure lines on the product at regular intervals.
- Before starting repair and maintenance work, make sure that all affected components are depressurised.

2.1.3 Electrical hazards

There is an immediate danger of fatal injury from electric shock when touching live parts. Damage to the insulation or individual components can be life-threatening.

- Only have qualified electricians carry out electrical work on the product.
- In case of damage to live components, switch off the voltage supply immediately and arrange for repair.
- Switch off the supply voltage before working on electrical components. Discharge residual voltage.
- Never bridge electrical fuses. Do not disable fuses. Use the correct current ratings when replacing fuses.
- Keep moisture away from live parts. Moisture can cause short-circuits.

2.1.4 Groups of persons requiring protection

- Children must not play with the product.
- This product can be used by children over 8 years of age and persons with limited abilities or lack of experience if they are supervised or instructed in the safe use of the product and understand the resulting hazards.
- Cleaning and maintenance must not be carried out by children.

2.2 Product-specific safety instructions

2.2.1 Signals and warning devices on the product

Labels on the product



Risk of electric shock

- ▶ Obey all warnings and safety instructions.
- ▶ Immediately replace illegible or damaged symbols and pictograms.

3 Product description

3.1 Intended use

- The water softener softliQ:MD12i is for exclusive use in industrial and commercial applications only.
- The water softener softliQ:MD12i must only and exclusively be used to soften cold water of drinking water quality.
- The water softener softliQ:MD12i is designed for softening to < 0.1 °dH (full salting).
- The water softener softliQ:MD12i is adjusted to the soft water demand expected at the time of installation, it is not suitable for major deviations in capacities. The nominal flow rate must not be exceeded under any circumstances.
- The softliQ water softener protects water pipes and connected water-carrying systems from scaling but cannot prevent corrosion.
- In addition to softening to < 0.1 °dH, the water softener softliQ:MD12i Gastronomy can also be used for producing a blending hardness.

3.1.1 Intended use

- For instance as pretreatment for reverse osmosis systems installed downstream
- For instance for heating systems, laboratories, restaurants and catering, ventilation and air conditioning systems

3.1.2 Application limits

- The water to be softened must be free of iron and manganese.
 - Iron < 0.2 mg/l
 - Manganese < 0.05 mg/l

3.2 Product components

Water softener softliQ:MD12i

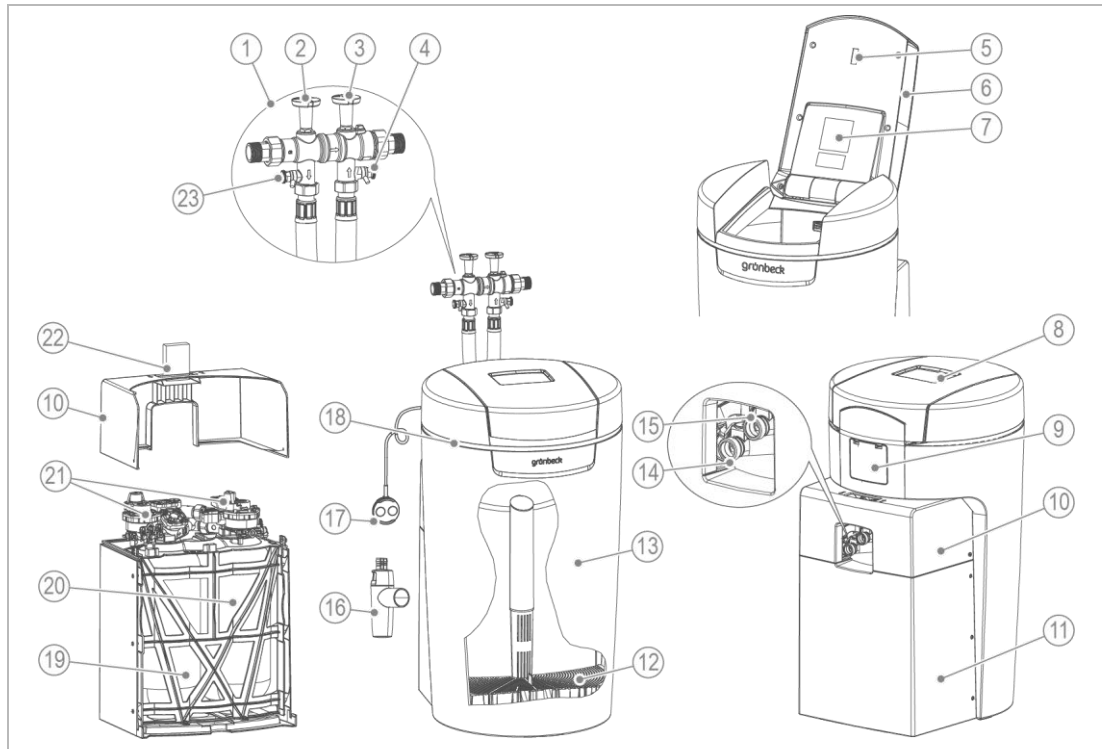

Designation	
1	Connection block
2	Raw water shut-off valve
3	Soft water shut-off valve
4	Sampling valve for soft water
5	Sensor of salt supply indicator
6	Brine tank lid
7	Type plate
8	Control unit (display)
9	Cover of connections (customer interface)
10	Housing of technical equipment, upper part
11	Housing of technical equipment, lower part
12	Sieve bottom

Designation	
13	Brine tank
14	Soft water connection
15	Raw water connection
16	Drain connection DN 50 acc. to DIN EN 1717
17	Water sensor
18	Illuminated LED ring
19	Exchanger 1
20	Exchanger 2
21	Control valves
22	Water test kit "Total hardness"
23	Sampling valve for raw water

Water softener softliQ:MD12i Gastro

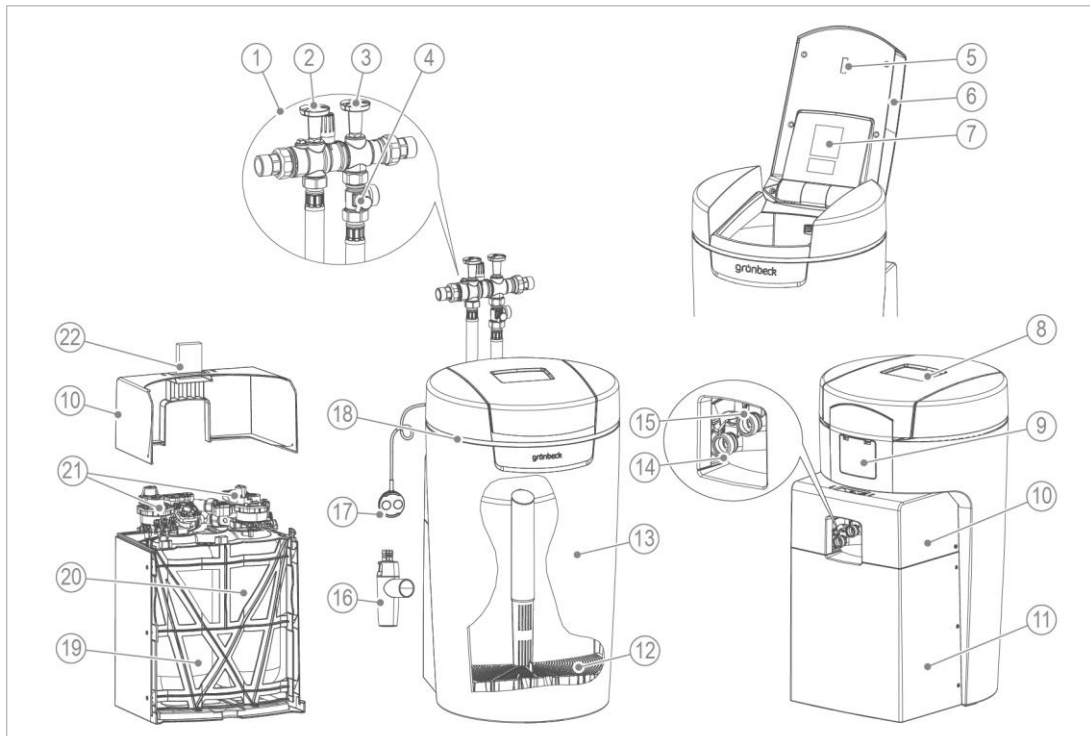

Designation		Designation	
1	Connection block	12	Sieve bottom
2	Raw water shut-off valve	13	Brine tank
3	Soft water shut-off valve	14	Soft water connection
4	Supplementary soft water outlet	15	Raw water connection
5	Sensor of salt supply indicator	16	Drain connection DN 50 acc. to DIN EN 1717
6	Brine tank lid	17	Water sensor
7	Type plate	18	Illuminated LED ring
8	Control unit (display)	19	Exchanger 1
9	Cover of connections (customer interface)	20	Exchanger 2
10	Housing of technical equipment, upper part	21	Control valves
11	Housing of technical equipment, lower part	22	Water test kit "Total hardness"

Salt supply indicator

Once per regeneration, a light sensor checks the filling level of the salt tablets. If the filling level is below the minimum, the control unit issues a warning message. The control unit calculates how many days the salt supply is expected to last and indicates this value in days.

Illuminated LED ring

The illuminated LED ring is designed as a visual signal during water treatment, operation and malfunction. In the standard setting, the illuminated LED ring behaves as follows:

- Lights up during water treatment
- Lights up during operation of the control unit

- Intermittent flashing in case malfunctions do occur
- Intermittent flashing in case of pre-alarm salt supply

The illuminated LED ring can be set to continuous illumination or be deactivated completely.

Water sensor

The water sensor detects water at the installation site of the softliQ system, reports this via the control unit of the softliQ or via Grünbeck's myProduct app and (if activated) triggers an audio signal.

Drain connection

The DN 50 drain connection with siphon is designed for professional installation in accordance with DIN EN 1717.

3.3 Functional description

3.3.1 Process

The softliQ water softener works according to the ion exchange process. The exchange of calcium and magnesium ions for sodium ions causes the water to become soft.

3.3.2 Function

The water softener softliQ:MD12i works in alternating operation to permanently ensure softened water of < 0.1 °dH. The two control valves are in operation alternately. A complete regeneration takes place as soon as the exchanger in operation is exhausted.

The softliQ:MD12i works with full salting.

As required by DIN standard 19636-100, the system releases a complete regeneration for hygienic reason no later than after four days without regeneration.

3.4 Admissible regenerant

softliQ water softeners must only be operated with the regeneration agent below:

- Salt tablets according to DIN EN 973 type A

3.5 Product registration



Registering your product extends your warranty by 1 year.

You can register your product as indicated below:

- Registration on Grünbeck’s website (www.gruenbeck.com).
- Registration using Grünbeck’s myProduct app (refer to chapter 7.3).
- Registration via the enclosed postcard.

3.6 Accessories

You can retrofit your product with additional accessories. Please contact your local Grünbeck representative or Grünbeck’s headquarters in Hoechststaedt/Germany for details.

Illustration	Product	Order no.
	Dosing system exaliQ:KC6-e	117 460
	Dosing system exaliQ:SC6-e	117 465
Electronically controlled dosing technology to protect the water pipe against corrosion or to stabilise the total hardness. Due to the integrated iQ interface, no additional water meter fitting is required.		
	Safety device protectliQ:A25	126 405
Product to protect against water damage in one and two-family homes. For other sizes, please inquire.		
	Delivery pump for regeneration water	188 800
To discharge the regeneration water into drain pipes located at a higher level.		

Illustration	Product	Order no.
	<p>Extension kit for connection hoses DN 25</p> <p>To extend the hose to 1.6 m.</p>	<p>187 660e</p>
	<p>90° connection angle - 1" (2 pieces)</p> <p>To direct the connection hoses closer along the softliQ in case of confined installation conditions.</p>	<p>187 865</p>
	<p>Supplementary blending valve</p> <p>To generate a blending water hardness. Can directly be connected to the connection block.</p>	<p>187 870</p>
	<p>Supplementary soft water outlet</p> <p>Installation in the soft water outlet between the water softener and the connection block, including sampling valve and non-return valve.</p>	<p>187 875</p>
	<p>Installation kit softliQ</p> <p>Space-saving combined connection of water softener and filter.</p>	<p>188 865</p>

3.7 Inputs and outputs of the control unit

The control unit features voltage-free inputs and outputs (refer to chapter 7.8)

3.7.1 Data circuit board

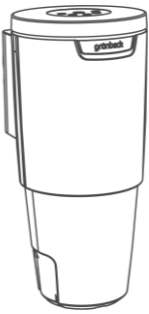
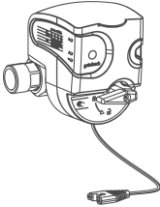
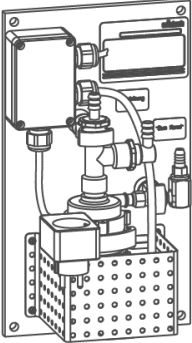
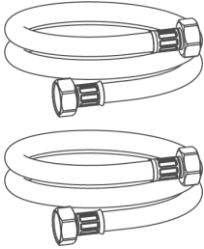
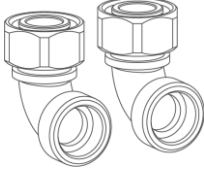
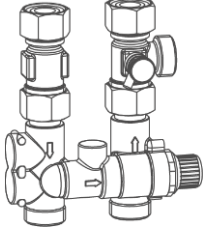
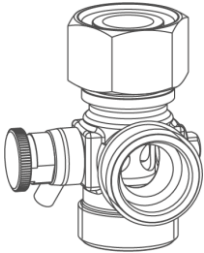
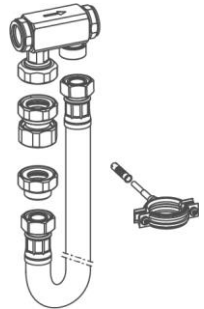
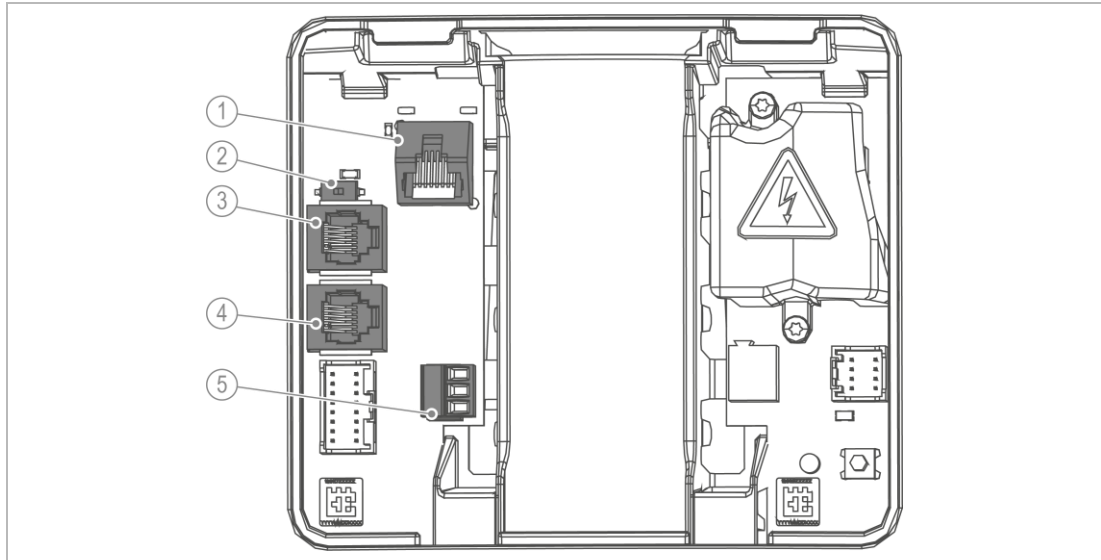

Designation	Designation
1 LAN connection	4 iQ Comfort 2
2 DIP switch	5 Water sensor (digital input)
3 iQ Comfort 1	

- ▶ Disconnect the water sensor if you want to assign the digital input a different function.
- ▶ Use LiYY 2x0.5 mm² or comparable cable as connection cable. (A larger line cross-section is unsuitable.)

Water sensor (digital input)

Pin assignment:

- Top terminal + middle terminal = Water sensor
- Bottom terminal + middle terminal = Regeneration release or regeneration lock
- ▶ Do not apply voltage signals to any of the 3 terminals.

iQ Comfort interfaces

The iQ Comfort interfaces are designed for interconnecting Grünbeck products such as exaliQ, for instance.

- ▶ Switch the DIP switch to ON (left position) to enable the iQ Comfort interfaces.

3.7.2 Power circuit board



WARNING Electrical voltage beneath the touch protection

- Electric shock
- ▶ Pull the mains plug before you remove the touch protection.

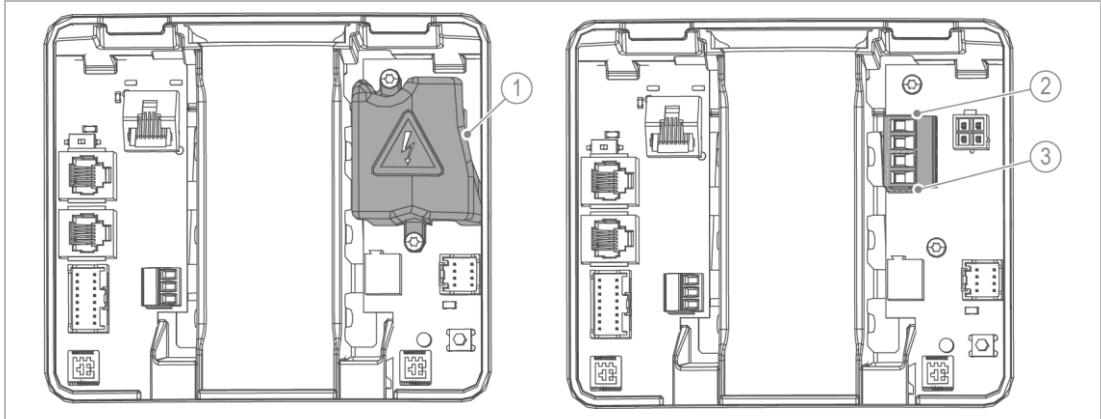

Designation	
1	Touch protection
2	Fault signal contact (upper two terminals) max. 230 V/max. 1 A (factory setting N.C.)

Designation	
3	Programmable output (lower two terminals) e.g. to connect the delivery pump for regeneration water max. 230 V/max. 1 A (factory setting Delivery pump for regeneration water)

1. Remove the touch protection to access the power circuit board.
2. Use the following connection lines for connection to the fault signal contact or the programmable output:
 - Flexible lines of quality H05xx F 2x0.75 mm² or comparable, because consumers operated with mains voltage might be connected. A larger line cross-section is unsuitable.
3. After the connection has been made, attach the touch protection.

4 Transport, set-up and storage

4.1 Shipping/delivery/packaging

- ▶ Upon receipt, immediately check for completeness and transport damage.
- ▶ In case of visible transport damage, proceed as follows:
 - Do not accept the delivery or only accept it under reserve.
 - Record the extent of damage on the transport documents or on the delivery note of the carrier.
 - Initiate a complaint.
- ▶ Only ship the product by forwarding agent (not by a parcel service provider).

4.2 Transport/Set-up

- ▶ Transport the product upright in its original packaging.
- ▶ Obey the symbols and instructions on the packaging.
- ▶ Only remove the packaging shortly before installation.
- ▶ Have two people carry the product.
- ▶ Use the recessed grips for carrying.

4.3 Storage

- ▶ Protect the product from the impacts below when storing it:
 - Dampness, moisture
 - Environmental impacts such as wind, rain, snow, etc.
 - Frost, direct sunlight, severe heat exposure
 - Chemicals, dyes, solvents and their vapours

5 Installation



The installation of a water softener represents a major intervention into the drinking water system and must be performed by a qualified specialist only.

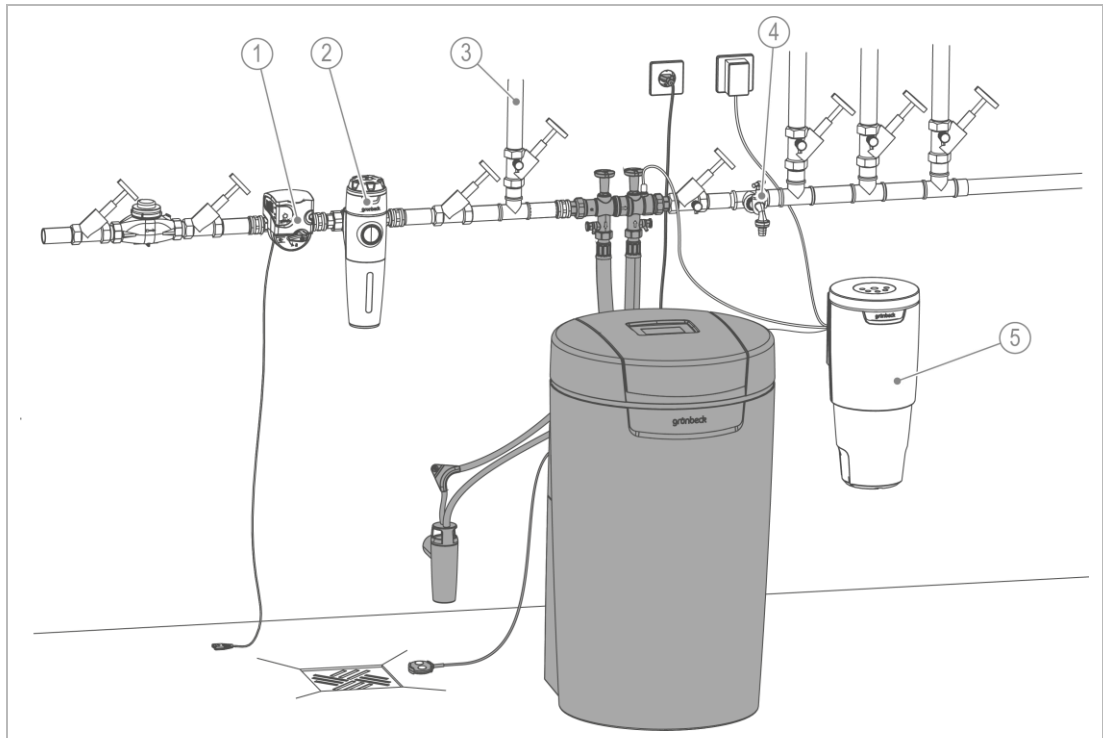

Designation

- 1 Safety device protectliQ
- 2 Drinking water filter pureliQ
- 3 Raw water pipe

Designation

- 4 Water withdrawal point
- 5 Dosing system exaliQ

5.1 Requirements for the installation site

- Obey the local installation directives, general guidelines and technical specifications.
- The installation site must be frost-proof and protect the product from direct sunlight, chemicals, dyes, solvents and their vapours.
- If the softened water is intended for human consumption as defined by the German Drinking Water Ordinance, the ambient temperature must not exceed 25 °C. For applications that are purely technical, the ambient temperature must not exceed 40 °C.
- A drinking water filter and, if required, a pressure reducer (e.g. fine filter pureliQ:KD) must be installed upstream of the product.
- A Schuko socket is required within a distance of approx. 1.2 m of the system. The socket outlet requires permanent power supply and must not be coupled with light switches, emergency heating switches or the like.
- A drain connection (DN 50) must be available to discharge the regeneration water.
- A floor drain suitable for the respective system size must be available at the installation site. Otherwise, a safety device such as a protectliQ (refer to chapter 3.6), or a safety device with water stop of the same quality must be installed. Floor drains that discharge to a lifting system do not work in case of a power failure.
- Make sure that lifting systems are resistant to salt water or use our delivery pump for regeneration water (refer to chapter 3.6).
- If required by the process installed downstream (e.g. a reverse osmosis system), a system separator must be used.
- The connection block features a non-return valve on the inlet side. Safety relief valves must therefore be installed in flow direction downstream of the softliQ.
- A water withdrawal point must be available near the product.
- In case of water pipes made of copper and/or galvanised steel, we recommend dosing exaliQ mineral solutions for corrosion protection (refer to chapter 3.6).

5.2 Checking the scope of supply

Water softener softliQ:MD12i

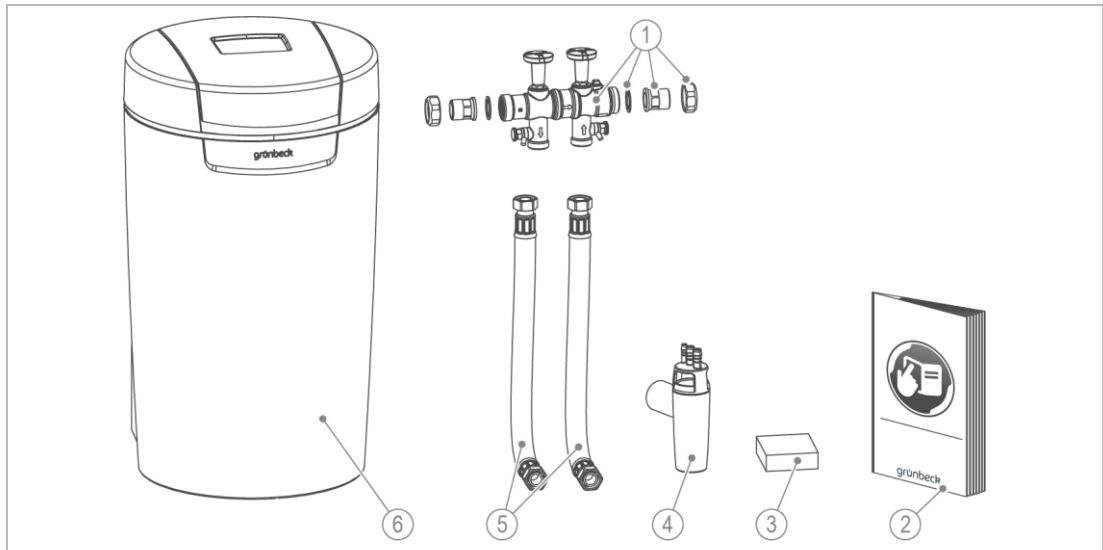

Designation

- | | |
|---|---|
| 1 | Connection block including water meter screw connection |
| 2 | Operation manual |
| 3 | Water test kit "Total hardness" |

Designation

- | | |
|---|--|
| 4 | Drain connection DN 50 acc. to DIN EN 1717 |
| 5 | 2 Connection hoses |
| 6 | Water softener completely pre-assembled |

Water softener softliQMD:12i Gastro

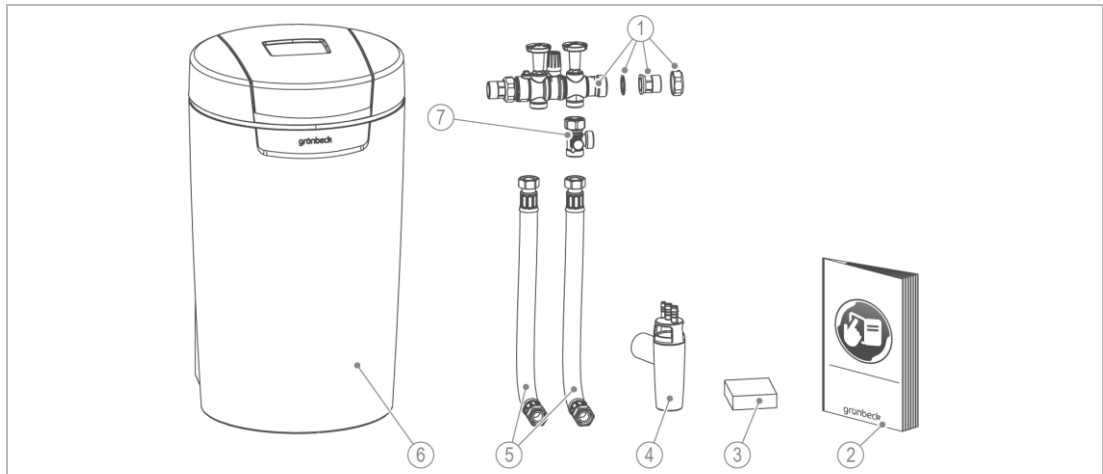

Designation

- | | |
|---|---|
| 1 | Connection block including water meter screw connection |
| 2 | Operation manual |
| 3 | Water test kit "Total hardness" |

Designation

- | | |
|---|--|
| 4 | Drain connection DN 50 acc. to DIN EN 1717 |
| 5 | 2 Connection hoses |
| 6 | Water softener completely pre-assembled |
| 7 | Supplementary soft water outlet |

► Check the scope of supply for completeness and damage.

5.3 Installing the product



WARNING

Contaminated drinking water due to stagnation.

- Infectious diseases
- ▶ Do not connect the product to the drinking water installation until immediately before start-up/commissioning.
- ▶ Only carry out the leak test during start-up/commissioning.

5.3.1 Installing the connection block

The connection block can be installed horizontally or vertically.

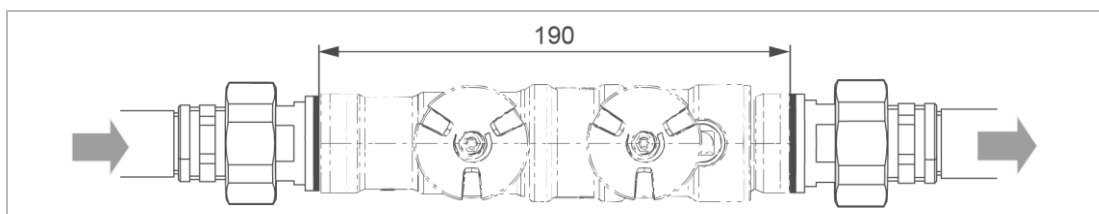

1. Install the water meter screw connection in the pipe.
2. Check the flow direction.
3. Respect the flow direction on the connection block (indicated by an arrow).
4. Make sure that the strainer insert is inserted on the inlet side.
5. Mount the connection block by tightening the union nuts without mechanical stress.
 - » The connection block is installed.

5.3.2 Installing the connection hoses

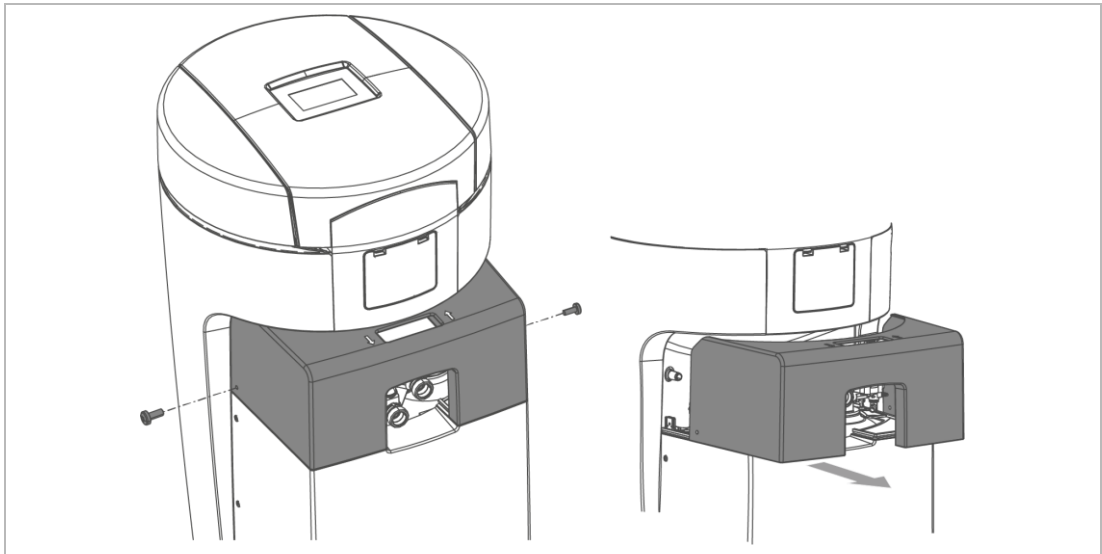

1. Loosen both screws on the side of the upper part of the housing for the technical equipment.
2. Remove the upper part of the housing of the technical equipment.
3. Respect the flow direction indicated by arrows on the connection block and on the control valve.

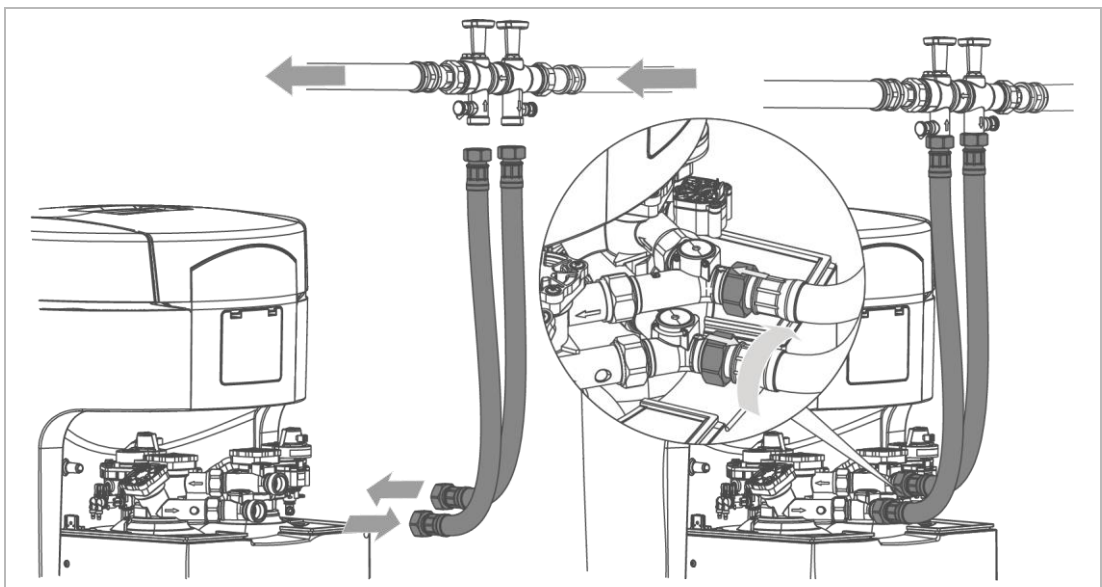

4. Install the connection hoses using suitable tools.
 - » The connection hoses are installed.

5.3.3 Establishing the waste water connection

NOTE: Waste water backing up due to kinked hoses.

- Water damage
- ▶ Run the hoses to the drain with a downward slope and without any kinks.

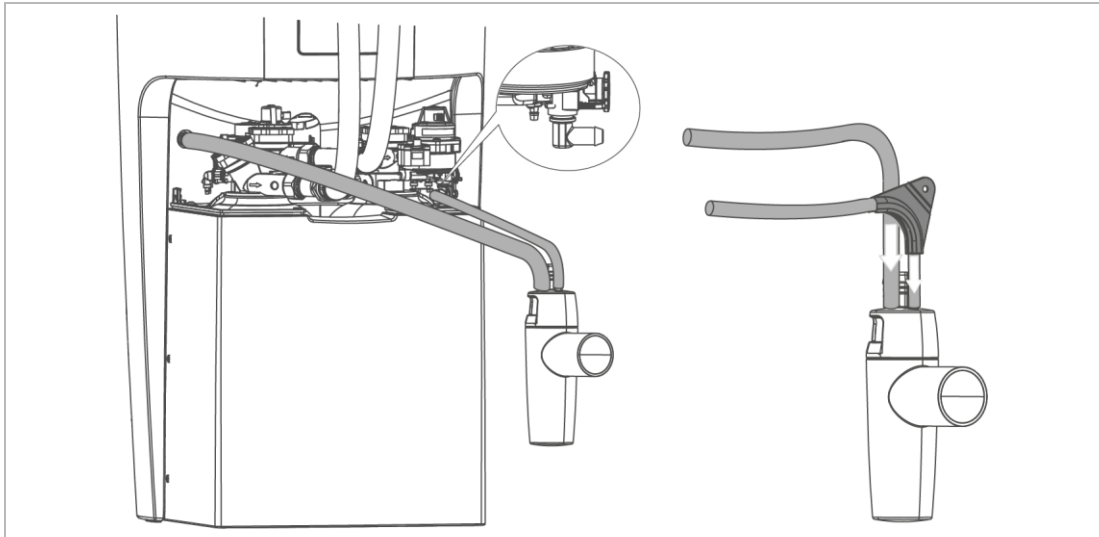





1. Shorten the flushing water hose (diameter 12 mm) to the required length.
 2. Attach the flushing water hose.
 - » The regeneration water emerges under pressure.
 3. Shorten the overflow hose (Ø 16 mm) to the required length.
 4. Run the overflow hose to the drain with a downward slope.
 5. Fasten the overflow hose.
 - » The installation is completed.
- ▶ Protect the product from contamination until it is started up by putting the protective cover (packaging) over the product.

6 Start-up/commissioning

6.1 Starting up the product

The start-up program assists you in starting up the product. The display guides you through the start-up procedure step-by-step. Input is required at some points, however.

- ▶ Follow the instructions on the touch display (refer to chapter 7.1).
- Use  or  to navigate through the program.
- Use  to go to the previous menu level.
- With , you confirm the selection and proceed to the next menu level.

6.1.1 Starting the start-up program

- ▶ Have salt tablets at hand.
- ▶ Have the value of the raw water hardness at hand.
 - b** Contact your water supply company and ask for the respective value or
 - c** Determine the value by using the water test kit (refer to chapter 7.6).
- 1. Plug in the mains plug.
- 2. Choose the language you want.
- 3. Select the continent where the system is installed.
- 4. Choose the **hardness unit** you want.
- 5. Select **start Guided start-up**.
 - » The start-up program starts.

6.1.2 Sequence of the start-up program

1. Confirm the proper installation of the product.
2. Select the drain connection used.
3. Check whether the hoses to the drain have been laid with a downward slope.
4. Place the water sensor flat on the floor.
5. Do not fill any water into the brine tank.
6. Fill salt tablets into the brine tank.
7. Set the time.
8. Set the date.
9. Set the raw water hardness.

- » The positioning process of the control valve starts.
- 10. Open the raw water shut-off valve.
- 11. Open the soft water shut-off valve.
 - » Water flows through the flushing water hose to the drain.

Venting program

The venting program runs automatically in 11 steps.

- 12. Start the venting program.
 - » After the venting program has been completed, the functional check starts.

Functional check

The functional check runs in 5 steps.

- 13. Have the water test kit at hand (refer to chapter 7.6).

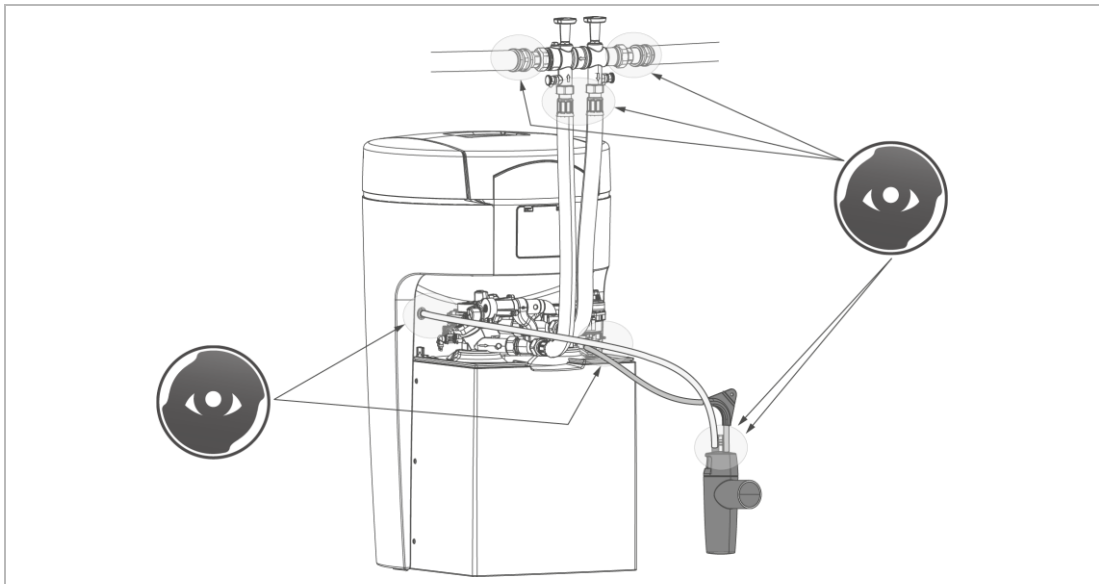

- 14. Visually check the connection points for leaks.

Test regeneration

The test regeneration takes approx. 33 minutes.

- 15. Start the test regeneration.
 - » After conclusion of the test regeneration, the start-up program is completed.
 - ▶ Check whether the water sensor is lying flat on the floor.
 - ▶ Fill in the start-up/commissioning log (refer to chapter 13).
 - » The start-up is completed.

Softened drinking water with optional blending

For the production of softened drinking water by means of the softliQ:MD12i, the specifications of the German Drinking Water Ordinance do apply.

- ▶ Set a soft water hardness between 3 °dH and 8 °dH.
- ▶ Do not exceed the max. sodium content of 200 mg/l.



In Austria, softened drinking water must have a soft water hardness of at least 8.4 °dH.

Softened drinking water by means of softliQ:MD12i Gastronomy

- ▶ After conclusion of the start-up program, set the desired soft water hardness (refer to chapter 7.7)

6.1.3 Manual start of the start-up program



The start-up program cannot be started while a regeneration is running.

Menu level>Start-up

- ▶ Press and hold for 2 seconds.
- ▶ Follow the instructions on the display.

The sequence of the steps is analogous to the automatic start-up-program.

6.2 Handing over the product to the owner/operator/operating company

- ▶ Explain to the owner/operator/operating company how the water softener works.
- ▶ Use the manual to brief the owner/operator/operating company and answer any questions.
- ▶ Inform the owner/operating company about the need for inspections and maintenance.
- ▶ Hand over all documents to the owner/operator/operating company for keeping.

7 Operation

NOTE: The valves of the system are operated electrically.

- Water can flow to the drain if there is a power failure during regeneration.
- ▶ In the event of a power failure, check your product and shut off the water supply, if necessary.

7.1 Touch display

7.1.1 Basic display

By default, the touch display is switched off.

- Tapping the touch display activates it.
- If there is no tap for 2 minutes, the control unit returns to the basic display. The display switches off.
- » Parameters that have not been saved are discarded.







Designation	
1	Menu level (permanently visible)
2	Work area/information display (changing symbols)

Designation	
3	Control elements (changing symbols)

7.1.2 Menu level

To access a menu, tap the corresponding button. The selected button is displayed in yellow. In the menus, you can start actions or change settings.

Illustration	Explanation
	Information This menu provides useful information on the water softener.
	Manual regeneration In this menu, you can manually start a regeneration (refer to chapter 7.5).
	Settings In this menu, you can adapt your water softener individually (refer to chapter 7.2).
	Water hardness In this menu, you can enter current values (refer to chapter 7.6).
	Start-up In this menu, you can start the automatic start-up program (refer to chapter 6.1).

7.1.3 Information display











Illustration	Explanation								
 1	<table border="1"> <tr> <td rowspan="2">blue</td> <td>In operation</td> </tr> <tr> <td>The system capacity decreases from top to bottom. One bar corresponds to 20 %. The light bars indicate the available system capacity.</td> </tr> <tr> <td rowspan="4">grey</td> <td>In regeneration</td> </tr> <tr> <td>The bars correspond to the following regeneration steps from the bottom upwards:</td> </tr> <tr> <td> <ul style="list-style-type: none"> • Filling brine tank (lowermost bar) • Salting + Slow rinse • Backwash • Washing out I (topmost bar is displayed halfway) • Standby (topmost bar is displayed halfway) • Washing out II (topmost bar is displayed in full) </td> </tr> <tr> <td></td> </tr> </table>	blue	In operation	The system capacity decreases from top to bottom. One bar corresponds to 20 %. The light bars indicate the available system capacity.	grey	In regeneration	The bars correspond to the following regeneration steps from the bottom upwards:	<ul style="list-style-type: none"> • Filling brine tank (lowermost bar) • Salting + Slow rinse • Backwash • Washing out I (topmost bar is displayed halfway) • Standby (topmost bar is displayed halfway) • Washing out II (topmost bar is displayed in full) 	
blue	In operation								
	The system capacity decreases from top to bottom. One bar corresponds to 20 %. The light bars indicate the available system capacity.								
grey	In regeneration								
	The bars correspond to the following regeneration steps from the bottom upwards:								
	<ul style="list-style-type: none"> • Filling brine tank (lowermost bar) • Salting + Slow rinse • Backwash • Washing out I (topmost bar is displayed halfway) • Standby (topmost bar is displayed halfway) • Washing out II (topmost bar is displayed in full) 								
 2									



Illustration	Explanation
	<p>Current flow rate</p> <p>The current flow rate is displayed as a numerical value and in the form of a "tachometer". If the nominal flow of the system is exceeded, the circular segments are red.</p>
 <p>Perform maintenance since ... days</p>	<p>Yellow symbol</p> <p>Maintenance due!</p> <ul style="list-style-type: none"> ▶ Contact technical service.
 <p>Leak at softliQ installation site</p>	<p>Yellow symbol</p> <p>Check the system site (detection by way of water sensor) for leaks and close the main valve of the building installation, if necessary.</p>
 <p>... days</p>	<p>Yellow symbol</p> <p>The salt supply will be used up soon. The expected time for the salt to last is displayed in days.</p> <ul style="list-style-type: none"> ▶ Fill salt tablets into the brine tank.
	<p>Red symbol</p> <p>The water softener is not working properly.</p> <ul style="list-style-type: none"> ▶ Fill salt tablets into the brine tank. ▶ Wait for 10 minutes. ▶ Start a manual regeneration (refer to chapter 7.5).
	<p>Red symbol</p> <p>The water softener is not working properly. A malfunction has occurred (refer to chapter 9).</p>
	<p>Wi-Fi symbol</p> <p>This is displayed when there is a Wi-Fi connection to a router.</p>
	<p>LAN symbol</p> <p>This is displayed when there is a LAN connection to a router.</p>
	<p>Cloud symbol</p> <p>This is displayed when the connection to the Grünbeck Cloud is established.</p>

7.1.4 Control elements

Button	Description
	Return to the basic display
◀ and ▶	Scroll through the menu level
▲ and ▼	Mark a selection, scroll to the menu items, select settings
↶	Return to the previous menu level, abort unwanted actions
✓	Confirm display messages and save settings



Buttons that currently do not have a function are displayed in light green.



To change a value or content, tap the corresponding field.
The field becomes white and can be changed.

In some extensive menus, functionally related parameters are grouped together into tabs under the header. Tap the tab to open the corresponding page. You can switch between the tabs using  or .

7.2 Menu structure

Values that can be selected or changed are displayed *in italics*.

Menu	Menu items	Values/settings		
Information	Basic display	Refer to chapter 7.1		
	System data	System flow rate Raw water hardness Capacity figure		
	Counter readings, date and time	Regeneration Soft water volume Perform maintenance in xx days (if activated) Date and time (display)		
	Contact details of installer	<i>Name</i>		
		<i>Phone no.</i> <i>Email</i> Technical service The technical service menu is reserved for technical service personnel and is protected by a code.		
Manual regeneration		 Press and hold for 2 seconds to start.		
Settings	Language	<i>German</i> <i>English</i> <i>French</i> <i>Spanish</i>	<i>Dutch</i> <i>Danish</i> <i>Italian</i> <i>Russian (planned)</i>	
	Hardness unit	<i>°dH</i> <i>°f</i> <i>mol/m³</i>	<i>ppm</i> <i>°e</i>	
	Date, time, time synchronisation			
	Date, time	Current time Current date	Current continent Current time zone	
	Time synchronisation	Switch-over DST to ST Get date/time automatically (NTP) URL NTP server		

Menu	Menu items	Values/settings
Cloud connection, Wi-Fi/LAN connection, network status		
	Cloud connection	Connection to Grünbeck Cloud Pairing of Grünbeck Cloud and user account URL Cloud URL certificate
	Wi-Fi/LAN connection	Network type Router connection Automatic IP address (DHCP) Automatic Wi-Fi connection (WPS) Wi-Fi search Wi-Fi networks found Wi-Fi password
	Network status	Parameter, value (display only)
Display, audio signal, illuminated LED ring		
	Display - Display in standby	<i>Deactivated</i> <i>Activated</i>
	Audio signal – Behaviour in case of malfunctions	<i>Deactivated</i> <i>Activated</i>
	Audio signal enabled from ... to ...	
	Illuminated LED ring – Function setting	<i>Water treatment + operation + malfunction</i> <i>Operation + malfunction</i> <i>Malfunction</i> <i>Permanent illumination</i> <i>Deactivated</i>
	Illuminated LED ring – Illuminated LED ring flashes on signal	<i>Deactivated</i> <i>Activated</i>
	Illuminated LED ring – Brightness	...%
Updates and profiles, manual update		
	 When switching to manual software updates, the latest security features and functions are not automatically available to you.	
	Software update	<i>Automatic</i> <i>Manual</i>
	Saving settings profile	No / Yes The parameter settings are saved here as a "Private" profile in the Grünbeck Cloud.
	Loading settings profile	Private profile Installer profile
	Software update	Only possible if software updates are not automatic!
	Resetting factory settings	Start
Device info, consumption histories, regeneration history		
	Device info	Software version Hardware version Controller serial number Maintenance interval
	Consumption histories	Water consumption Salt consumption
	Regeneration history	
Water hardness	Setting the water hardness	 Press and hold for 2 seconds to start. Raw water
Start-up	Start-up	 Press and hold for 2 seconds to start.

7.3 Connection to Grünbeck Cloud



The use of the Grünbeck Cloud and app functionalities depends on the service availability of the required Azure services in the data centre region of the respective country. Geopolitical changes or restrictions in the respective country can limit or prevent the availability of the services of the data centre currently located in the EU.

It is possible to control your softliQ water softener via a mobile device and to request information.

To do so, Grünbeck’s myProduct app must be installed on your mobile device.

The connection between your water softener and the mobile device does not work directly, but via the Grünbeck Cloud.

The connection between Grünbeck’s myProduct app and the control unit of the softliQ system is established in the following way:



Designation	
1	Grünbeck product
2	Router

Designation	
3	Grünbeck Cloud
4	Mobile device

As soon as a user account has been created via Grünbeck’s myProduct app and the anonymous data is assigned to your user account by pairing, the data is personalised as defined by the Data Protection Act.

7.3.1 Installing Grünbeck's myProduct app

Grünbeck's myProduct app is the link between your Grünbeck product and your mobile device. You can access your Grünbeck product all over the world.



- ▶ Download Grünbeck's myProduct app and install it on your mobile device.
- ▶ Create your personal user account.
- ▶ Add your softliQ to your user account in the Grünbeck myProduct app using + .
- ▶ Follow the instructions of Grünbeck's myProduct app.

Product registration

Using Grünbeck's myProduct app, you can conveniently register your product.

- ▶ Call up Registration and Product registration in the device overview of Grünbeck's myProduct app.
- ▶ Enter your personal data.
 - » Registration of your product extends your warranty by 1 year.

7.3.2 Allowing connection to the Grünbeck Cloud

After the connection to the Cloud has been allowed and the connection to the router has been established, the control unit automatically checks whether a new firmware update is available in the Cloud.

- ▶ Do not interrupt the power supply while a firmware download and processing is in progress (max. 20 minutes).

If your softliQ water softener is linked to your user account in the Grünbeck Cloud, you will be notified by email in the event of a malfunction.

7.3.3 Establishing a connection to the router

Menu level>Settings>Wi-Fi/LAN connection



As soon as the connection to the Grünbeck Cloud has been allowed and a connection to the router has been established, the control unit cyclically sends anonymous data to the Grünbeck Cloud.

7.3.4 URL certificate

To ensure that the connection to the Grünbeck Cloud is working securely, the control unit always downloads the current URL certificate.

The entry below must be present in Settings/Cloud connection/URL certificate:

`prodeugruenbeckfirmware.blob.core.windows.net/cert`

- ▶ Check whether the entry is present.
- ▶ Add the entry, if required.

7.4 Refilling salt tablets

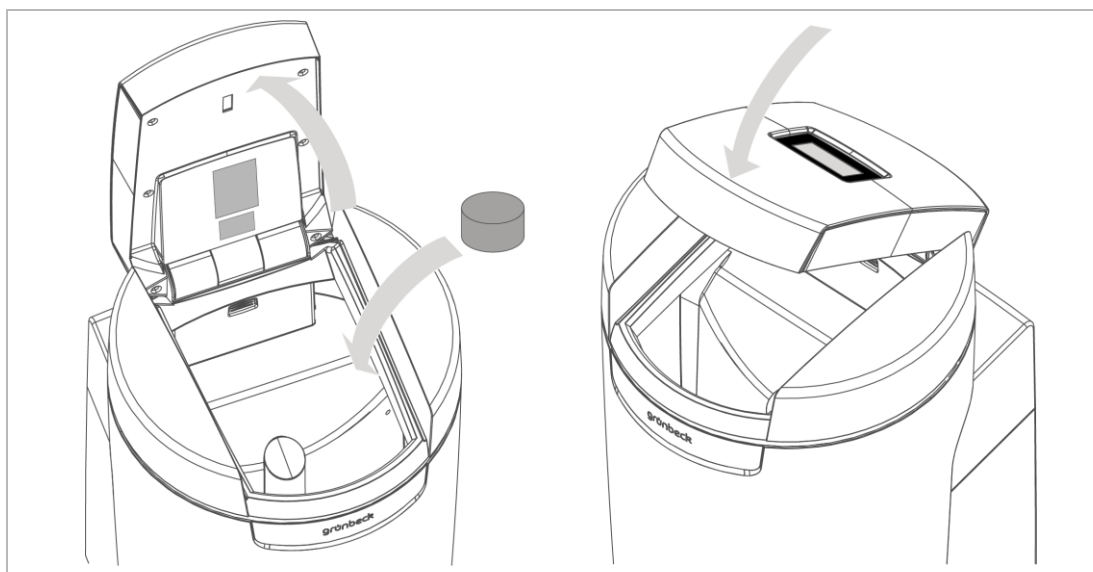

The salt supply in the brine tank must always be higher than the water level. Normally, the water level is approx. 1 cm above the sieve bottom.

1. Open the brine tank lid.



The sensor of the salt supply indicator is located in the brine tank lid of the softliQ system. This sensor does not work with laser light and thus is safe for the eyes. The function of the salt supply indicator is explained in chapter 3.2.

2. Fill salt tablets into the brine tank.

3. Dispose of the dust-like fine fraction from the bag with your residual waste.
4. Close the brine tank lid.
5. Document the refill in the operation log (refer to chapter 13).

7.5 Starting a manual regeneration

Menu level>Manual regeneration

A manual regeneration is necessary in the following cases:

- If the product is put into operation again after a longer period of standstill.
- After maintenance or repair work was performed.
- After a longer power failure.

The exchangers are regenerated one after the other.

7.6 Determining and entering the water hardness

The water test kit is designed for the determination of the water hardness in °dH or in °f. The unit mol/m³ (mmol/l) can be determined from °f.

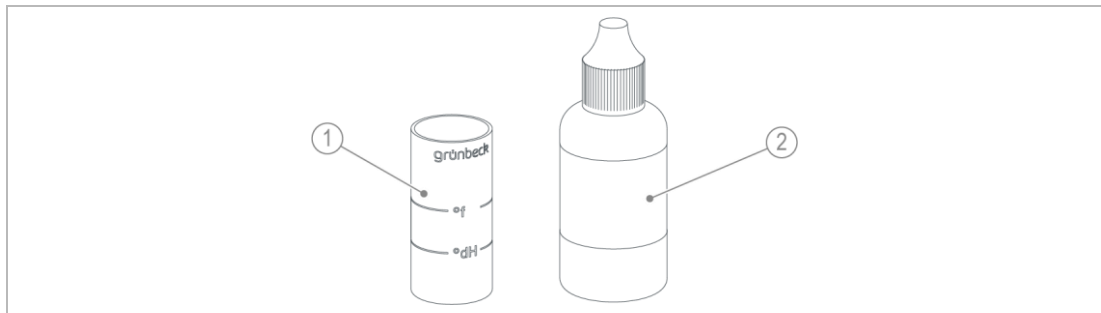

Designation	Designation
5 Test tube	6 Titration solution

7.6.1 Taking a water sample

1. Open a sampling valve on the connection block.
 - a Use the raw water sampling valve to take a raw water sample.
 - b Use the soft water sampling valve to take a soft water sample.
2. Take a water sample using the °dH test tube:
 - a Fill the test tube up to the °dH mark to determine the water hardness in °dH.
 - b Fill the test tube up to the °f mark (x 0.1 = mol/m³) in order to determine the water hardness in °f, mol/m³ or mmol/l.

7.6.2 Determining the water hardness in °dH/°f

1. Add one drop of titration solution (1 drop = 1 °dH or 1 °f).
2. Shake the test tube until the titration solution is mixed with the water.
3. In case of red colouring, repeat steps 1 and 2 and count the drops until the colour changes to green.
 - » If the colour changes from red to green, the water hardness has been determined.





- Test tube filled up to the °dH mark: 6 drops = 6 °dH.
- Test tube filled up to the °f mark: 6 drops = 6 °f.

7.6.3 Determining the water hardness in mol/m³ (mmol/l)

1. Determine the water hardness in °f as described.
2. Divide the value in °f by 10.
6 drops = 6 °f = 0.6 mol/m³ = 0.6 mmol/l.
 - » You get the water hardness in mol/m³.

7.6.4 Entering the water hardness

Menu level > Water hardness

1. Press and hold  for 2 seconds.
2. Tap **Raw water hardness**.
3. Enter the value of the raw water hardness.
4. Confirm with .

7.7 Setting the blending valve



The blending valve is only included in the scope of supply of water softener softliQ: MD12i Gastronomy. An optional blending valve is available as accessory (refer to chapter 3.6)



The blending valve must only be set while water is flowing (approx. 400 – 600 l/h).
Recommended soft water hardness: 3 – 6 °dH (5...11 °f)

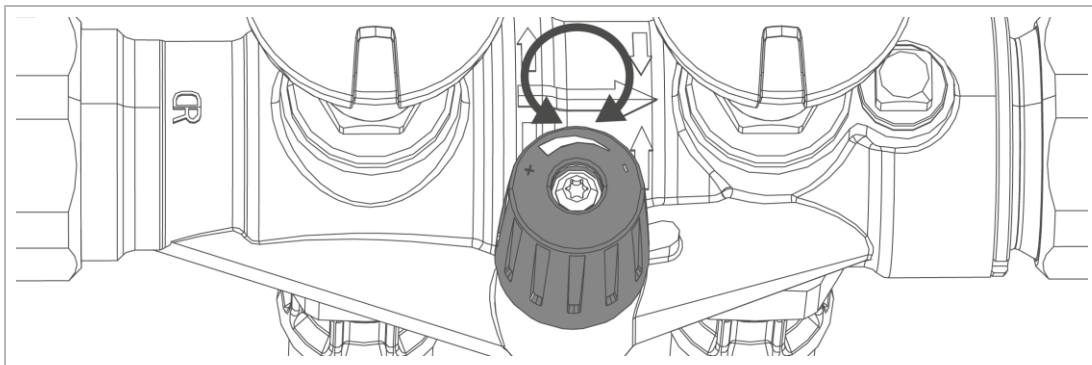

1. Measure the raw water hardness (refer to chapter 7.6).
2. Set the blending valve in the middle position.
3. Measure the soft water hardness (refer to chapter 7.6).
4. Set the soft water hardness to the desired value:
 - ▶ Turn the blending valve to the right.
 - » The soft water hardness is reduced.
 - ▶ Turn the blending valve to the left.
 - » The soft water hardness is increased.

7.8 Installer level (Code 005)



The settings described here must be made by qualified specialists only.



While the function below is in progress, the product must not be disconnected from mains:

- Filling operating water into brine tank

Otherwise, the reference position of the exchanger that is not in the operation must be found manually afterwards (grey symbol in the basic display).

Menu level>Information>Contact data of installer

1. Tap .
2. Enter the Code using the numerical keypad.
3. Confirm with .
 - » You can change parameters and values.

Menu structure

Menu items		Settings/remarks
Wi-Fi access point (Can only be selected in connection with Grünbeck's complementary mySettings app for qualified specialists.)	Page 1/2	Activate Deactivate
	Page 2/2	IP address
		SSID
		Password
Exchanger 1	Page 1/2	Flow rate, l/h
		Capacity figure, m ³ x °dH
		Remaining capacity, m ³
		Regeneration step
	Page 2/2	Regeneration flow rate, l/h
		Last regeneration, date/time Above xxx, %
Exchanger 2	Page 1/2	Flow rate, l/h
		Capacity figure, m ³ x °dH
		Remaining capacity, m ³
		Regeneration step
	Page 2/2	Regeneration flow rate, l/h
		Last regeneration, date/time Above xxx, %
Flow rate Exchanger 1	(Display only)	Exchanger 1 Peak value, m ³ /h for xxxxx, min
Flow rate Exchanger 2	(Display only)	Exchanger 2 Peak value, m ³ /h for xxxxx, min
Water volumes	(Display only)	Soft water Exchanger 1, m ³ Soft water Exchanger 2, m ³ Make-up water volume, l
Counter readings	(Display only)	Salt consumption, kg Regeneration counter
Find referencing Exchanger 1	Start	Moving to reference position. Ongoing regeneration is aborted. After completion, the factory setting becomes active.
Find referencing Exchanger 2	Start	
Filling operating water into brine tank	Start	Filling the brine tank to a minimum water level (e.g. after cleaning the brine tank). After completion, the factory setting is active again.
Test regeneration Exchanger 1	Start	Functional check of all components involved in the regeneration.
Test regeneration Exchanger 2	Start	
Test regeneration Exchangers 1 & 2	Start	Performing test regeneration of both exchangers immediately one after the other.
Saving settings profile	None (factory setting)	
	Yes	Saving all current parameter settings of the control unit in the Grünbeck Cloud, so that they can be loaded into the control unit again later, if necessary. Here, the parameter settings are saved as "Installer" profile in the Grünbeck Cloud.
Function Programmable output	Delivery pump for regeneration water (factory setting)	This setting is required in connection with the delivery pump for regeneration water available as an accessory (refer to chapter 3.6). Contact closed (delivery pump for regeneration water running) during the regeneration steps First filtrate, Salting, Slow rinse and Backwash.
	Regeneration message	Contact closed during the entire regeneration.
	Release residual hardness monitoring	Contact closed as long as there is no water withdrawal 0 °dH
Function Fault signal contact	Normally closed (N.C.) (factory setting)	Contact closed if mains voltage is applied and there is no fault.
	Normally open (N.O.)	Contact closed if there is a fault.

Menu items		Settings/remarks
Function Programmable input	Leak detection (factory setting)	If the water sensor detects a leak at the installation site of the softliQ, the message Leak at softliQ installation site is displayed.
	Regeneration lock	The regeneration lock is active as long as the contact at the programmable input is closed; manually released and automatic regenerations after a power failure take priority. A regeneration that has already been started is not aborted.
	Release of regeneration	Starting regeneration when the contact at the programmable input closes.

8 Maintenance and repair

Maintenance and repair include cleaning, inspection and maintenance of the product.



WARNING Contaminated drinking water

- Infectious diseases
- ▶ Pay attention to hygiene when working on the product.



The responsibility for inspection and maintenance is subject to local and national requirements. The owner/operator/operating company is responsible for compliance with the prescribed maintenance and repair work.



By concluding a maintenance contract you make sure that all maintenance work will be carried out on time.

- ▶ Only use genuine spare and wearing parts from Grünbeck.

8.1 Cleaning

NOTE Do not clean the product with cleaning agents containing alcohol/solvents

- Plastic components are damaged
- Varnished surfaces are affected
- ▶ Use a mild/pH-neutral soap solution.
- ▶ Only clean the outside of the product.
- ▶ Do not use any strong or abrasive cleaning agents.
- ▶ Wipe the housing with a damp cloth.



The technical service personnel clean the brine tank once a year during maintenance.

8.2 Intervals



By way of regular inspections and maintenance, malfunctions can be detected in time and product failures can be prevented.

For this purpose, DIN EN 806-5 recommends semi-annual and annual maintenance.

Task	Interval	Execution
Inspection	2 months	<ul style="list-style-type: none"> • Check for function • Check for leaks • Check salt supply
Maintenance	6 months	<ul style="list-style-type: none"> • Evaluate condition and consumption of salt • Check water sensor
	annually	<ul style="list-style-type: none"> • Check operating values and function • Clean components • Check wearing parts and replace them, if necessary.

8.3 Inspection

You as owner/operator/operating company can do the regular inspections yourself. Regular inspections increase the operational reliability of your product.

- ▶ Carry out an inspection at least every 2 months.

To carry out an inspection, proceed as follows:

1. Check the soft water hardness (refer to chapter 7.6).
2. Check that there are enough salt tablets in the brine tank.



The level of salt tablets in the brine tank must always be higher than the water level. Normally, the water level is approx. 1 cm above the sieve bottom.

3. Check the connection hoses for leaks.
4. Check the control valve to the drain for leaks.



No water must drip from the flushing water hose during operation (blue symbol in the basic display).

8.4 Maintenance

8.4.1 Semi-annual maintenance

To carry out the semi-annual maintenance, proceed as follows:

1. Evaluate the salt consumption subject to the water volume consumed.
2. Check the condition of the salt (no salt clumps!).
Break up incrustations with a suitable tool.
3. Check the water sensor for function by bridging it with a metal object.

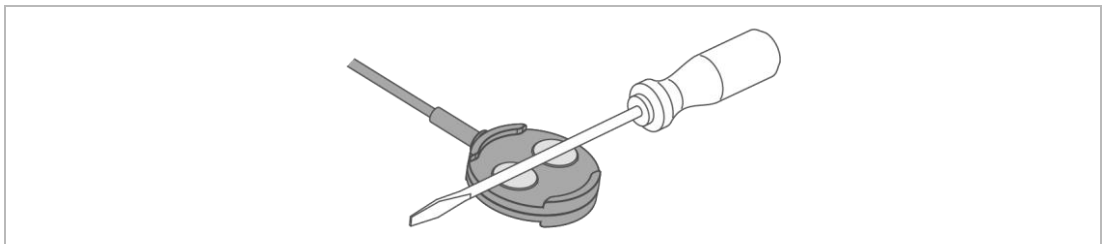

- » The water sensor is working if the water softener issues a warning message after 30 seconds at the latest.

8.4.2 Annual maintenance



Carrying out annual maintenance work requires specialist knowledge. The maintenance work must be carried out by technical service personnel only.

In addition to the semi-annual maintenance, the following work needs to be done:

Operating values

1. Measure the raw water hardness.
2. Compare the raw water hardness with the setting in the control unit and adjust it accordingly.
3. Measure the soft water hardness.
4. Compare the soft water hardness with the setting in the control unit and adjust it accordingly.
5. Read the water and flow pressure.
6. Read the residential water meter.
7. Read the regeneration counter.
8. Read the soft water meter.
9. Read out the error memory.

Maintenance work on the exchangers

The work below must be carried out on every exchanger.

10. Check the hose connections for leaks and damage.
11. Check the soft water meter for pulse emission (current flow during operation, refer to chapter 7.1.3).
12. Check all cables and connections for damage and a tight fit.
13. Check the injector and the injector sieve and clean them, if necessary.
14. Check the brine filling orifice in the brine connection angle (red).
15. Check the brine valve and the level electrodes and clean them, if necessary.
16. Clean the brine tank.
17. Start a manual regeneration.
18. Check the suction power of the injector.
19. Check the chlorine current during salting.
20. Check the regeneration counter for function during backwash (installer level).
21. Check the control valve at the drain outlet in operating position for leaks (flushing water hose, filling hose and suction hose).
22. Check the filling hose and the suction hose to the brine valve for leaks.
23. Reset the maintenance interval, if activated.
24. Enter the maintenance in the operation log (refer to chapter 13).

8.5 Consumables

Product	Order no.
Regeneration salt tablets (25 kg) acc. to DIN EN 973 type A	127 001
Water test kit "Total hardness"	170 187

8.6 Spare parts

For spare parts and consumables please contact your local Grünbeck representative who you may find on the internet at www.gruenbeck.com.

8.7 Wearing parts

Wearing parts are listed below:

- Control valve: seals, disc pair, injector and chlorine cell

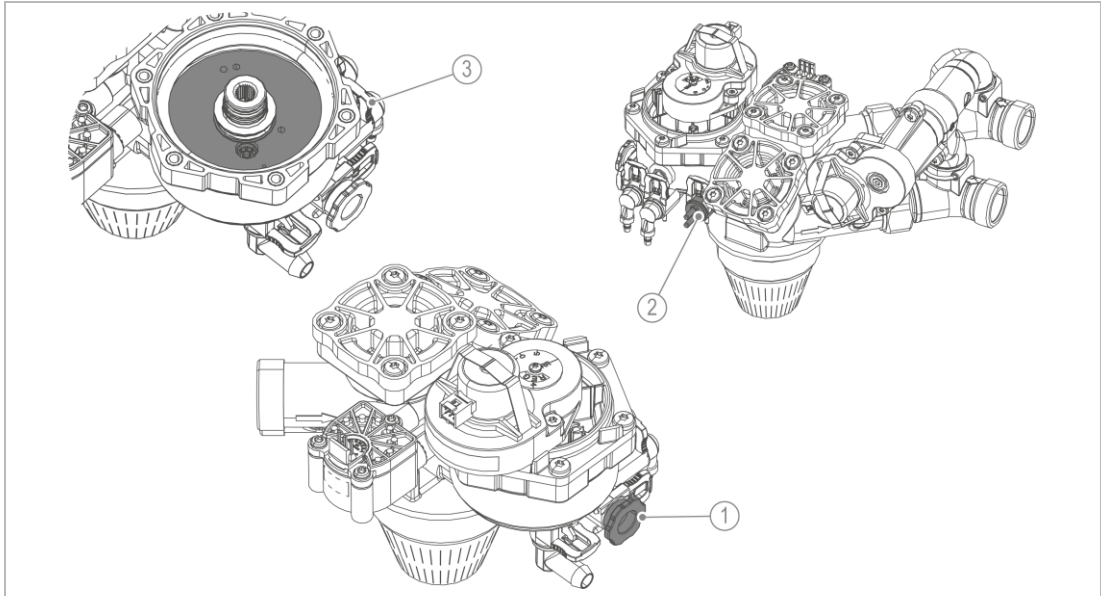

Designation	
1	Injector (with circlip)
2	Chlorine cell (with circlip)

Designation	
3	Regeneration disc pair (with flow stabiliser)

- Brine valve: seals and electrodes.

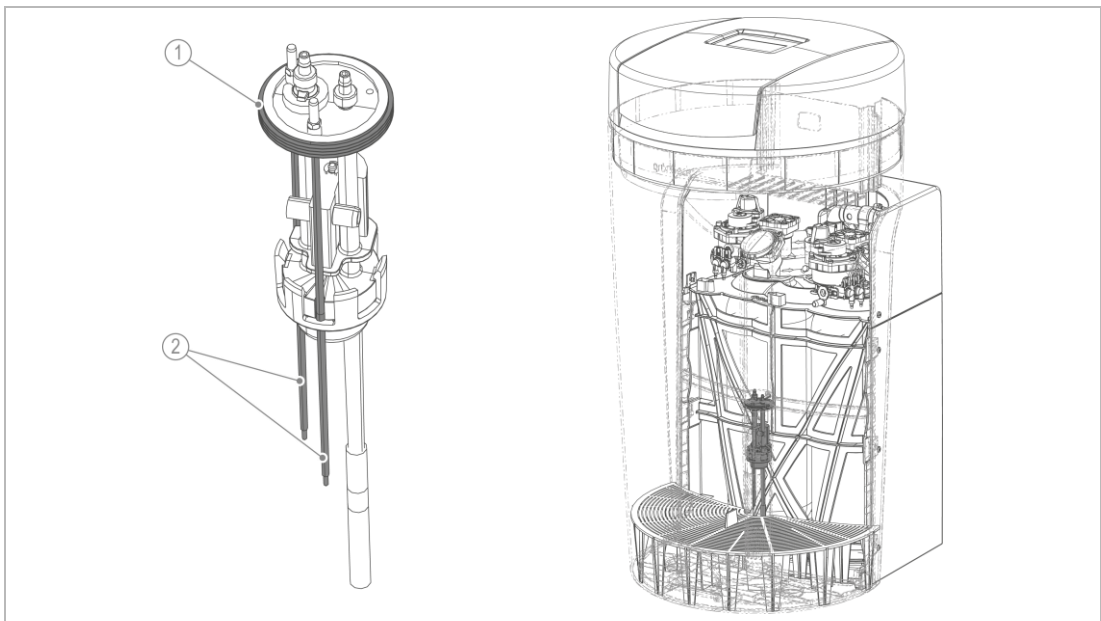

Designation	
7	Seal

Designation	
8	Electrodes

9 Troubleshooting



WARNING

Contaminated drinking water due to stagnation.

- Infectious diseases
- ▶ Have malfunctions repaired immediately.



The softliQ water softener indicates malfunctions on the display. As soon as a fault appears, the touch display changes to the basic display and remains active until the condition has been rectified.

- ▶ If you cannot eliminate malfunctions with the instructions given below, contact the technical service.
- ▶ Have your system data (refer to chapter 1.2) at hand.







9.1 Display messages





1. Acknowledge the display message with **Rectify**.
2. If the fault occurs again, compare the display message with the table below.

9.1.1 Warning signals (yellow symbols)





Display	Explanation	Remedy
 Service overdue by ... days	Only displayed if maintenance interval is activated.	▶ Contact technical service.
 Leak at softliQ installation site	Water sensor has electrical connection.	▶ Check whether water is leaking. ▶ If necessary, close the main valve of the building installation.
 Salt supply low! Please refill! Sufficient for: xy days (Order no. 127 001)	Salt supply low.	▶ Fill salt tablets into the brine tank. ▶ Acknowledge with Rectify .

9.1.2 Fault signals (red symbols)

Display	Explanation	Remedy
 Power failure > 5 minutes	<p>Only displayed if detection was activated by technical service personnel.</p> <p>Upon return of power, the water softener will perform a regeneration.</p> <p>If there is a power failure, any regeneration in progress at the time is stopped and continued afterwards.</p>	<ul style="list-style-type: none"> ▶ Check the electrical connection. ▶ Set the time. ▶ Start a manual regeneration (refer to chapter 7.5).
 Salt supply used up! Refill immediately! (Order no. 127 001)	Hollow area below the salt.	▶ Break up incrustations with a suitable tool.
	Salt supply used up.	<ul style="list-style-type: none"> ▶ Fill salt tablets into the brine tank. ▶ Acknowledge with Rectify.
	Water pressure too low.	▶ Increase the flow pressure to min. 2.0 bar.
	Chlorine cell worn. Brine filling orifice, injector, injector sieve or brine valve clogged.	▶ Contact technical service.
 Drive failure of regeneration control valve!	Step monitoring of regeneration motor or connecting cable defective.	▶ Contact technical service.
 Regeneration water meter Volume not reached!	Regeneration water meter is not emitting pulses. Connecting cable defective. Water supply interrupted. Safety float on brine valve closed.	<ul style="list-style-type: none"> ▶ Check water supply. ▶ Contact technical service.
 Soft water meter defective	Connecting cable defective.	<ul style="list-style-type: none"> ▶ Check water supply. ▶ Contact technical service.
 Regeneration water meter defective	Connecting cable defective.	<ul style="list-style-type: none"> ▶ Check water supply. ▶ Contact technical service.
 System is not drawing brine from the brine tank effectively	Minimum contact during Salting not reached. Monitoring time exceeded. Injector clogged or raw water pressure too low.	▶ Contact technical service.

Display	Explanation	Remedy
 Nominal flow exceeded	<p>Only displayed if monitoring was activated by qualified specialist.</p> <p>System is being operated with excessive flow rates.</p>	<ul style="list-style-type: none"> ▶ Reduce flow rate. ▶ If the fault persists, contact technical service.
 Water loss to drain	<p>Water loss to drain.</p>	<ul style="list-style-type: none"> ▶ Contact technical service.
 Power supply failure of drives!	<p>Short-circuit on the motor or on the connecting cable to the motor.</p>	<ul style="list-style-type: none"> ▶ Contact technical service.
 System overloaded Capacity already used up before end of regeneration	<p>One exchanger is being regenerated while the other is already exhausted.</p>	<p>Symbol on the left: Exchanger 1 Symbol on the right: Exchanger 2 Only displayed if detection is activated.</p> <ul style="list-style-type: none"> ▶ Reduce water withdrawal.

Fault signals during start-up/commissioning

Display	Explanation	Remedy
 Fault during start-up (Venting)	<p>Time monitoring of venting (backwash) has responded. No flow was detected at the regeneration water meter.</p>	<ul style="list-style-type: none"> ▶ Check whether the shut-off valves on the connection block are open.
 Fault during start-up (Filling brine tank)	<p>Time monitoring for filling the brine tank has responded.</p>	<ul style="list-style-type: none"> ▶ Check whether the raw water shut-off valve is open. ▶ Acknowledge with Rectify. ▶ Repeat start-up/commissioning.
 Fault during start-up (Chlorine current too low)	<p>Current monitoring during test regeneration has responded.</p>	<ul style="list-style-type: none"> ▶ Fill salt tablets into the brine tank. ▶ Acknowledge with Rectify. ▶ Repeat start-up/commissioning.
 Fault during start-up (Referencing)	<p>Step monitoring of regeneration motor or connecting cable defective.</p>	<ul style="list-style-type: none"> ▶ Acknowledge with Rectify. ▶ Repeat start-up/commissioning. ▶ Contact technical service if the fault reoccurs.

9.2 Other observations

Observation	Meaning	Remedy
No soft water	Excessive water consumption (water softener has exceeded its capacity).	<ul style="list-style-type: none"> ▶ Restrict your water consumption to the maximum flow rate permitted (refer to chapter Fehler! Verweisquelle konnte nicht gefunden werden.). ▶ Start a manual regeneration (refer to chapter 7.5).
	Water softener does not have a permanent power connection.	▶ Check the electrical connection.
	Soft water meter is not emitting pulses.	▶ Contact technical service.
	Raw water hardness is set too low.	<ul style="list-style-type: none"> ▶ Measure the raw water hardness (refer to chapter 7.6). ▶ Update the value in the control unit.
	Water supply is interrupted.	▶ Check whether the shut-off valves on the connection block are open.
Resin beads in flushing water hose or in tap aerator	Defective jet system.	▶ Contact technical service.
Water pressure at the withdrawal point is too low. (Pressure loss too high.)	Resin might be polluted by undissolved particles.	▶ Contact technical service if the problem originates from the water softener.
Start-up program: During the venting program or test regeneration, the display remains unchanged for more than 20 minutes.	Connection hoses are connected the wrong way round (raw water and soft water).	<ul style="list-style-type: none"> ▶ Check the connection hoses. <ul style="list-style-type: none"> ▶ Close both shut-off valves at the connection block. ▶ Start a manual regeneration. ▶ Swap the connection hoses. ▶ Open the shut-off valves.
Rattling noise at the connection block during water withdrawal		

For information on malfunctions regarding the Grünbeck Cloud, go to the following address on the internet: <https://www.gruenbeck.de/en/become-a-water-expert/faq/>



10 Decommissioning

10.1 Temporary standstill

In accordance with DIN 19636-100, your water softener regenerates after 4 days, even if the capacity has not yet been exhausted by that time. The stagnation of water is prevented. It is not necessary to temporarily shut down your product.

- ▶ Leave your product connected to electricity and water.

If you still want to temporarily shut down your product, proceed as follows:

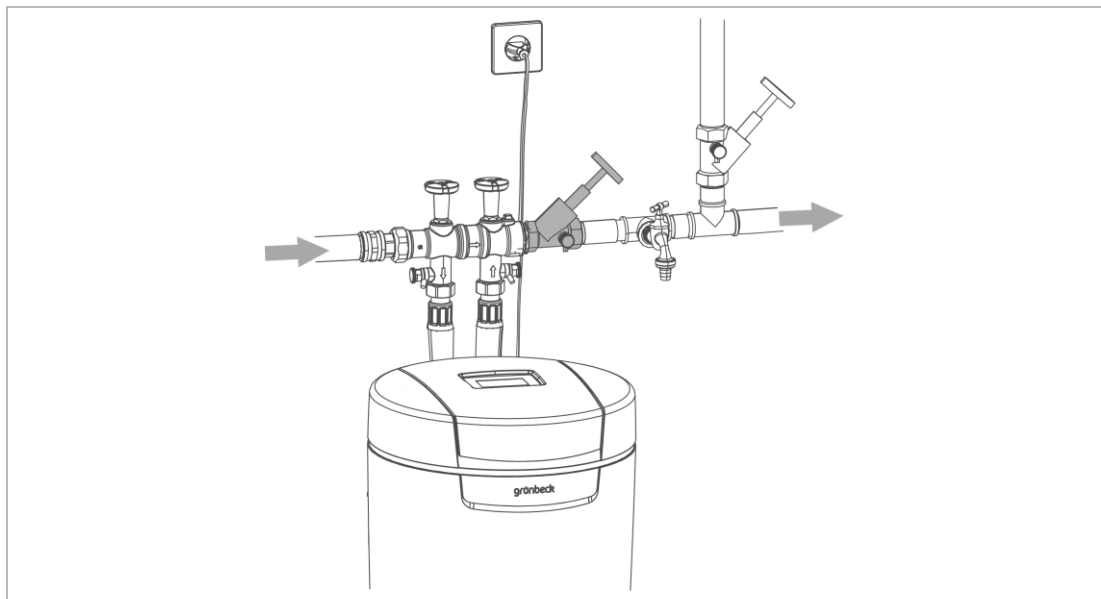

- ▶ Close the shut-off valve downstream of the product.
 - » The product remains in an operating state which is considered to be safe with regard to hygiene and which is admissible according to DIN EN 19636-100.

10.2 Final shutdown

Refer to the next chapter.

11 Dismantling and disposal

11.1 Deleting personal data

For security reasons, delete your personal data before disposing of your product.

- ▶ Please contact Grünbeck's technical service for this.

11.2 Dismantling



Dismantling a water softener represents a major intervention into the drinking water system and must be performed by a qualified specialist only.

1. Close the raw water shut-off valve.
2. Open a water withdrawal point.
3. Wait for a few seconds.
 - » The pressure in the product and the pipe network is being relieved.
4. Close the water withdrawal point.
5. Pull the mains plug.
6. Keep a collecting vessel (e.g. a bucket) handy to catch escaping water.
7. Disconnect the connection hoses from the product.
8. Disconnect the connection hoses from the connection block.
9. Remove the connection block.
10. Close the gap in your drinking water installation, e.g. by using an adjusting piece (order no. 128 001).
11. Drain the brine tank.
12. Drain all liquids from the product.

11.3 Disposal

- ▶ Obey the applicable national regulations.

Packaging

- ▶ Dispose of the packaging in an environmentally sound manner.

NOTE

Danger to the environment due to incorrect disposal

- Packaging materials are valuable raw materials that can be reused in many cases.
- Incorrect disposal can cause hazards to the environment.
 - ▶ Dispose of packaging materials in an environmentally sound manner.
 - ▶ Obey the local disposal regulations.
- ▶ If necessary, commission a specialist company with the disposal.

Product



If this symbol (crossed-out wheelie bin) is on the product, it means that this product or its electrical and electronic components must not be disposed of as household waste.

- ▶ Find out about the local regulations on the separate collection of electrical and electronic products.
- ▶ Make use of the collection points available to you for the disposal of your product.
- ▶ If your product contains batteries or rechargeable batteries, dispose of them separately from your product.



For more information on take-back and disposal, go to www.gruenbeck.de.

12 Technical specifications

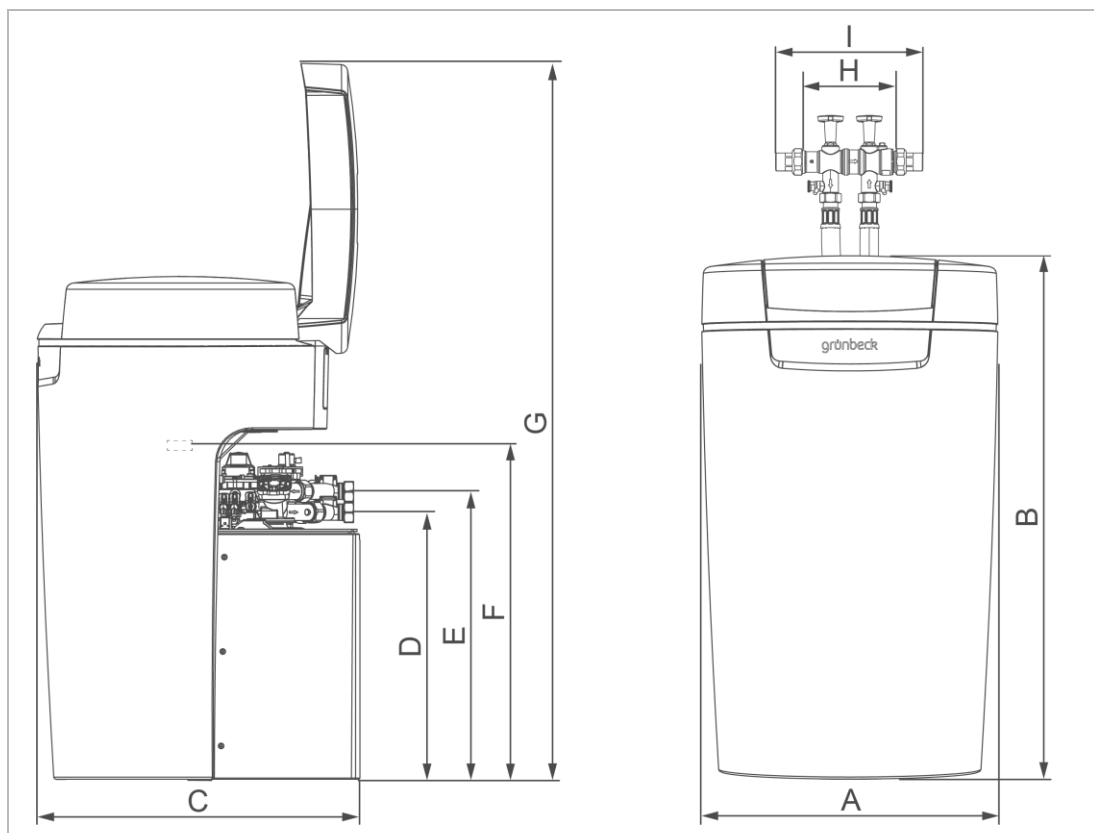

Dimensions and weights			softliQ:MD12i (Gastro)
A	System width	mm	525
B	System height	mm	912
C	System depth	mm	580
D	Connection height of control valve (soft water)	mm	480
E	Connection height of control valve (raw water)	mm	518
F	Height of safety overflow of brine tank	mm	540
G	Height with open lid	mm	1290
H	Installation length without screw connection	mm	190
I	Installation length with screw connection	mm	271
Operating weight, approx.		kg	140
Shipping weight, approx.		kg	46

Connection data		softliQ:MD12i (Gastro)
Nominal connection diameter		DN 25 (1" male thread)
Drain connection		DN 50
Rated voltage range	V	100 – 250
Rated frequency	Hz	50 – 60
Rated load (during regeneration, temporarily)	W	14
Power input during softening, with display, Wi-Fi and illuminated LED ring being switched off	W	< 3.5
Protection/protection class		IP 54/☐
Wi-Fi frequency band	GHz	2.4

Performance data		softliQ:MD12i (Gastro)
Nominal pressure		PN 10
Rated pressure	MPa/bar	1.0/10
Operating pressure (recommended)	bar	2.0 – 8.0 (4.0)
Nominal flow (0 °dH, 0 °f, 0 mol/m³)	m³/h	1.2
Pressure loss at nominal flow	bar	0.5
Nominal capacity	m³ x °dH m³ x °f mol	2 x 15 2 x 27 2 x 2.7
Capacity per kg of regeneration salt	mol/kg	2.4
Regeneration time for a complete regeneration (4 bar)	min	30

Filling volumes and consumption data		softliQ:MD12i (Gastro)	
Resin volume	l	2 x 7.5	
Salt consumption* (both exchangers)	kg	2.24	
Regeneration salt supply	kg	≤ 95	
Salt consumption	per m³ and °dH per m³ and °f per m³ and mol	kg/(m³ x °dH) kg/(m³ x °f) kg/mol	0.07 0.039 0.39
Flushing water flow rate	m³/h	≤ 0.4	
Total waste water volume* (both exchangers)	l	58	
Waste water volume*	per m³ and °dH per m³ and °f per m³ and mol	l/(m³ x °dH) l/(m³ x °f) l/mol	1.93 1.07 10.7

*For a complete regeneration

General data		softliQ:MD12i (Gastro)
Water temperature	°C	5 – 30
Ambient temperature (technical application)	°C	5 – 40
Humidity (non-condensing)	%	≤ 90
ÜA registration number The Office of the Vienna Provincial Government – City of Vienna		R-15.2.3-21-17496
Order no. softliQ:MD12i		187 140
Order no. softliQ:MD12i Gastronomy		187140000100

13 Operation log



- ▶ Document the initial start-up/commissioning and all maintenance activities.
- ▶ Copy the maintenance report.

Water softener softliQ:MD12i

Serial no.: _____

Start-up/Commissioning log

Customer					
Name:					
Address:					
Installation/Accessories					
softliQ connected to Cloud	<input type="checkbox"/> Wi-Fi		<input type="checkbox"/> LAN		<input type="checkbox"/> No
Drinking water filter (make/type):					
Drain connection acc. To DIN EN 1717	<input type="checkbox"/> Yes		<input type="checkbox"/> No		
Floor drain available	<input type="checkbox"/> Yes		<input type="checkbox"/> No		
Safety device	<input type="checkbox"/> Yes		<input type="checkbox"/> No		
Regeneration water lifting system	<input type="checkbox"/> Yes		<input type="checkbox"/> No		
Make:					
Dosing	<input type="checkbox"/> Yes		<input type="checkbox"/> No		
Active agent:					
Operating values					
Water pressure	bar				
Residential water meter reading	m ³				
Hardness unit	°dH	°f	mol/m ³	°e	°ppm
Raw water hardness (measured)	<input type="checkbox"/>	<input type="checkbox"/>	<input type="checkbox"/>	<input type="checkbox"/>	<input type="checkbox"/>
Raw water hardness (set)	<input type="checkbox"/>	<input type="checkbox"/>	<input type="checkbox"/>	<input type="checkbox"/>	<input type="checkbox"/>
Soft water hardness (measured)	<input type="checkbox"/>	<input type="checkbox"/>	<input type="checkbox"/>	<input type="checkbox"/>	<input type="checkbox"/>
In case of softliQ:MD12i Gastronomy:					
Blending hardness (measured)					
Remarks					
Start-up					
Company:					
Service technician:					
Work time certificate (no.):					
Date/signature:					

BA_100097340000_en_084_softliQ-MD12i.docx

Documentation of salt consumption

1. Read off the soft water meter.

Information>Counter readings, date and time>Soft water volume

2. Enter the value read.

3. Enter the amount of salt refilled

4. Evaluate the salt consumption subject to the water volume consumed.

Date	Counter reading of soft water meter	Amount of salt refilled in kg	Salt consumption OK	
			<input type="checkbox"/> Yes	<input type="checkbox"/> No
			<input type="checkbox"/> Yes	<input type="checkbox"/> No
			<input type="checkbox"/> Yes	<input type="checkbox"/> No
			<input type="checkbox"/> Yes	<input type="checkbox"/> No
			<input type="checkbox"/> Yes	<input type="checkbox"/> No
			<input type="checkbox"/> Yes	<input type="checkbox"/> No
			<input type="checkbox"/> Yes	<input type="checkbox"/> No
			<input type="checkbox"/> Yes	<input type="checkbox"/> No
			<input type="checkbox"/> Yes	<input type="checkbox"/> No
			<input type="checkbox"/> Yes	<input type="checkbox"/> No
			<input type="checkbox"/> Yes	<input type="checkbox"/> No
			<input type="checkbox"/> Yes	<input type="checkbox"/> No
			<input type="checkbox"/> Yes	<input type="checkbox"/> No
			<input type="checkbox"/> Yes	<input type="checkbox"/> No
			<input type="checkbox"/> Yes	<input type="checkbox"/> No
			<input type="checkbox"/> Yes	<input type="checkbox"/> No
			<input type="checkbox"/> Yes	<input type="checkbox"/> No
			<input type="checkbox"/> Yes	<input type="checkbox"/> No
			<input type="checkbox"/> Yes	<input type="checkbox"/> No
			<input type="checkbox"/> Yes	<input type="checkbox"/> No
			<input type="checkbox"/> Yes	<input type="checkbox"/> No
			<input type="checkbox"/> Yes	<input type="checkbox"/> No
			<input type="checkbox"/> Yes	<input type="checkbox"/> No
			<input type="checkbox"/> Yes	<input type="checkbox"/> No
			<input type="checkbox"/> Yes	<input type="checkbox"/> No
			<input type="checkbox"/> Yes	<input type="checkbox"/> No
			<input type="checkbox"/> Yes	<input type="checkbox"/> No
			<input type="checkbox"/> Yes	<input type="checkbox"/> No
			<input type="checkbox"/> Yes	<input type="checkbox"/> No
			<input type="checkbox"/> Yes	<input type="checkbox"/> No
			<input type="checkbox"/> Yes	<input type="checkbox"/> No
			<input type="checkbox"/> Yes	<input type="checkbox"/> No
			<input type="checkbox"/> Yes	<input type="checkbox"/> No
			<input type="checkbox"/> Yes	<input type="checkbox"/> No
			<input type="checkbox"/> Yes	<input type="checkbox"/> No
			<input type="checkbox"/> Yes	<input type="checkbox"/> No
			<input type="checkbox"/> Yes	<input type="checkbox"/> No
			<input type="checkbox"/> Yes	<input type="checkbox"/> No
			<input type="checkbox"/> Yes	<input type="checkbox"/> No
			<input type="checkbox"/> Yes	<input type="checkbox"/> No
			<input type="checkbox"/> Yes	<input type="checkbox"/> No
			<input type="checkbox"/> Yes	<input type="checkbox"/> No
			<input type="checkbox"/> Yes	<input type="checkbox"/> No
			<input type="checkbox"/> Yes	<input type="checkbox"/> No
			<input type="checkbox"/> Yes	<input type="checkbox"/> No
			<input type="checkbox"/> Yes	<input type="checkbox"/> No
			<input type="checkbox"/> Yes	<input type="checkbox"/> No
			<input type="checkbox"/> Yes	<input type="checkbox"/> No
			<input type="checkbox"/> Yes	<input type="checkbox"/> No
			<input type="checkbox"/> Yes	<input type="checkbox"/> No
			<input type="checkbox"/> Yes	<input type="checkbox"/> No
			<input type="checkbox"/> Yes	<input type="checkbox"/> No
			<input type="checkbox"/> Yes	<input type="checkbox"/> No
			<input type="checkbox"/> Yes	<input type="checkbox"/> No
			<input type="checkbox"/> Yes	<input type="checkbox"/> No
			<input type="checkbox"/> Yes	<input type="checkbox"/> No
			<input type="checkbox"/> Yes	<input type="checkbox"/> No
			<input type="checkbox"/> Yes	<input type="checkbox"/> No
			<input type="checkbox"/> Yes	<input type="checkbox"/> No

Maintenance no.: _____



- ▶ Enter the measured values and operating data.
- ▶ Confirm the tests with **OK** or record any repairs done.

Operating values	
Raw water hardness measured/set	/
Soft water hardness measured/set	/
Soft water hardness 0 °dH test (Exchanger 1)	<input type="checkbox"/> OK
Soft water hardness 0 °dH test (Exchanger 2)	<input type="checkbox"/> OK
In case of softliQ:MD12i Gastronomy: Blending hardness (measured)	<input type="checkbox"/> OK
Operating pressure	bar
Residential water meter reading	m ³
Soft water meter	m ³
Regeneration counter	m ³

Reading out the error memory			
	Error	Date	Time
1			
2			
3			
4			
5			
6			
7			
8			
9			
10			

Maintenance work	Exchanger 1 OK	Exchanger 2 OK
Hose connections checked for leaks and damage	<input type="checkbox"/>	<input type="checkbox"/>
Soft water meter checked for pulse output	<input type="checkbox"/>	<input type="checkbox"/>
Regeneration water meter checked for pulse output	<input type="checkbox"/>	<input type="checkbox"/>
Cables checked for damage and tight fit	<input type="checkbox"/>	<input type="checkbox"/>
Injector and injector sieve cleaned/checked	<input type="checkbox"/>	<input type="checkbox"/>
Chlorine cell checked	<input type="checkbox"/>	<input type="checkbox"/>
Level electrodes of brine valve cleaned/checked	<input type="checkbox"/>	<input type="checkbox"/>
Brine tank cleaned	<input type="checkbox"/>	<input type="checkbox"/>
Salt tablets checked for cleanliness	<input type="checkbox"/>	<input type="checkbox"/>
Reference position moved to manually (C 005)	<input type="checkbox"/>	<input type="checkbox"/>
Suction power of the injector checked during Salting: 0.1 l in 60 – 120 s	<input type="checkbox"/>	<input type="checkbox"/>
Current at the chlorine cell during Salting	<input type="checkbox"/>	<input type="checkbox"/>
Water sensor checked for function	<input type="checkbox"/>	<input type="checkbox"/>
Product/control valve checked for leaks	<input type="checkbox"/>	<input type="checkbox"/>
Drain connection cleaned	<input type="checkbox"/>	<input type="checkbox"/>
Flushing water hose checked for leaks during operation		
Filling and suction hose to the brine valve checked for leaks during operation	<input type="checkbox"/>	<input type="checkbox"/>
Maintenance interval reset	<input type="checkbox"/>	<input type="checkbox"/>

Remarks

Carried out by

Company: _____

Service technician: _____

BA_100097340000_en_084_softliQ-MD12i.docx

EU Declaration of Conformity

In accordance with the Radio Equipment Directive 2014/53/EU, Appendix VI



This is to certify that the system designated below meets the safety and health requirements of the applicable European guidelines in terms of its design, construction and execution.

This certificate becomes void if the system is modified in any way not approved by us.

Water softener softliQ:MD12i

Serial no.: Refer to type plate

The aforementioned system also complies with the following directives and provisions:

- RoHS 2011/65/EU

The following harmonised standards have been applied:

- EN 60335-1:2012 + AC:2014 + A11:2014
- EN 61000-3-2:2014 Class A
- ETSI EN 300 328 V 2.1.1 (2016-11)
- EN 61000-6-2:2005 + AC:2005
- EN 61000-6-3:2007 + A1:2011+AC:2012

The following national standards and regulations have been applied:

- ETSI EN 301 489-1 V2.1.1 section 8 and/or 9 (version included in addition: V1.9.2)
- DIN EN 14743:2007-09
- ETSI EN 301 489-17 V3.1.1
- DIN 19636-100:2008-02

Responsible for documentation:

Mirjam Müller

Manufacturer:

Grünbeck Wasseraufbereitung GmbH
Josef-Grünbeck-Str. 1
89420 Hoechstädt/Germany

Hoechstädt/Germany, 18/03/2021



ppa. Dietmar Ladenburger
Technical Director
Member of the Executive Board

Publisher's information

Technical documentation

Should you have any questions or suggestions regarding this operation manual, please contact Grünbeck Wasseraufbereitung GmbH's Department for Technical Documentation directly.

Email: dokumentation@gruenbeck.de

Grünbeck Wasseraufbereitung GmbH
Josef-Grünbeck-Str. 1
89420 Hoechstädt
GERMANY

 +49 9074 41-0

 +49 9074 41-100

info@gruenbeck.com
www.gruenbeck.com



For more information go to
www.gruenbeck.com